



Advanced Energy Design Guide for Small Warehouses and Self-Storage Buildings

Achieving 30% Energy Savings Toward a Net Zero Energy Building



Developed by:
American Society of Heating, Refrigerating, and Air-Conditioning Engineers
The American Institute of Architects
Illuminating Engineering Society of North America
U.S. Green Building Council
U.S. Department of Energy

Advanced Energy Design Guide for Small Warehouses and Self-Storage Buildings

This is an ASHRAE Design Guide. Design Guides are developed under ASHRAE's Special Publication procedures and are not consensus documents. This document is an application manual that provides voluntary recommendations for consideration in achieving greater levels of energy savings relative to minimum standards.

This publication was developed under the auspices of ASHRAE Special Project 110.

ADVANCED ENERGY DESIGN GUIDE—WAREHOUSE COMMITTEE

Ron Jarnagin, *Chair*

Merle McBride
Vice Chair

Michael Lane
IESNA Representative

Don Colliver
Steering Committee Ex Officio

Dan Nall
AIA Representative

Jay Enck
USGBC Representative

Daniel Walker
MBMA Representative

Lilas Pratt
ASHRAE Staff Liaison

James McClendon
Consultant

AEDG STEERING COMMITTEE

Don Colliver, *Chair*

Markku Allison
AIA

Dru Crawley
U.S. DOE

Terry Townsend
ASHRAE

John Hogan
Consultant (ASHRAE TC 2.8)

Rita Harrold
IESNA

Harry Misuriello
Consultant (ASHRAE TC 7.6)

Brendan Owens
USGBC

Jerry White
Consultant (ASHRAE Standard 90.1)

Advanced Energy Design Guide for Small Warehouses and Self-Storage Buildings

Achieving 30% Energy Savings Toward a Net Zero Energy Building

American Society of Heating, Refrigerating and Air-Conditioning Engineers, Inc.
The American Institute of Architects
Illuminating Engineering Society of North America
U.S. Green Building Council
U.S. Department of Energy

ISBN 978-1-933742-22-9

©2008 American Society of Heating, Refrigerating
and Air-Conditioning Engineers, Inc.
1791 Tullie Circle, N.E.
Atlanta, GA 30329
www.ashrae.org

All rights reserved.

Printed in the United States of America

Printed on 15% post-consumer waste using soy-based inks.

Cover design and illustrations by Emily Luce, Designer.
Cover photograph courtesy of InterfaceFLOR.

ASHRAE has compiled this publication with care, but ASHRAE has not investigated, and ASHRAE expressly disclaims any duty to investigate, any product, service, process, procedure, design, or the like that may be described herein. The appearance of any technical data or editorial material in this publication does not constitute endorsement, warranty, or guaranty by ASHRAE of any product, service, process, procedure, design, or the like. ASHRAE does not warrant that the information in the publication is free of errors, and ASHRAE does not necessarily agree with any statement or opinion in this publication. The entire risk of the use of any information in this publication is assumed by the user.

No part of this book may be reproduced without permission in writing from ASHRAE, except by a reviewer who may quote brief passages or reproduce illustrations in a review with appropriate credit; nor may any part of this book be reproduced, stored in a retrieval system, or transmitted in any way or by any means—electronic, photocopying, recording, or other—without permission in writing from ASHRAE.

Library of Congress Cataloging-in-Publication Data

Advanced energy design guide for small warehouses and self-storage buildings : achieving 30% energy savings toward a net zero energy building.

p. cm.

Includes bibliographical references.

Summary: "Fourth in series that provides recommendations for achieving 30% energy savings over minimum requirements of ANSI/ASHRAE/IESNA Standard 90.1-1999 for warehouses up to 50,000 ft² and self-storage buildings using heating and AC equipment. Helps achieve advanced energy savings without detailed calculations or analyses. Includes recommendations for all 8 US climate zones"--

Provided by publisher.

ISBN 978-1-933742-22-9 (softcover)

1. Buildings--Energy conservation. I. American Society of Heating, Refrigerating and Air-Conditioning Engineers.

TJ163.5.B84A273 2008

725'.350472--dc22

2008009031

ASHRAE STAFF

SPECIAL PUBLICATIONS

Christina Helms

Editor

Cindy Sheffield Michaels

Associate Editor

James Madison Walker

Assistant Editor

Michshell Phillips

Administrative Assistant

PUBLISHING SERVICES

David Soltis

Group Manager

Jayne Jackson

Publication Traffic Administrator

PUBLISHER

W. Stephen Comstock

Contents

Acknowledgments · VII

Abbreviations and Acronyms · IX

Chapter 1	Introduction · 1
	Contents · 2
	How to Use this Guide · 3
Chapter 2	Integrated Process for Achieving Energy Savings · 5
	Design (Including Planning and Pre-Design) · 6
	Construction · 11
	Acceptance · 11
	Occupancy · 11
	Operation · 11
	Energy Goals and Strategies · 12
Chapter 3	Recommendations by Climate · 17
	Zone 1 · 20
	Zone 2 · 22
	Zone 3 · 24
	Zone 4 · 26
	Zone 5 · 28
	Zone 6 · 30
	Zone 7 · 32
	Zone 8 · 34

Chapter 4	Technology Examples and Case Studies · 37
	Climate Zone 4—Tacoma Power & Light New Shops Building · 38
	Climate Zone 5—Steelcare Inc. Warehouse · 40
	Climate Zone 7—BigHorn Home Improvement Center · 42
Chapter 5	How to Implement Recommendations · 45
	Quality Assurance · 45
	Envelope · 50
	Opaque Envelope Components · 50
	Fenestration: Vertical Glazing and Skylights (Envelope) · 57
	Lighting · 61
	Daylighting · 61
	Electric Lighting Design · 64
	HVAC · 72
	Service Water Heating · 82
	Bonus Savings · 83
	Ventilation Control · 83
	Plug Loads · 84
	Exterior Lighting · 86
Appendix A	Envelope Thermal Performance Factors · 87
Appendix B	Climatic Zones for Mexico and Canada · 89
Appendix C	Additional Resources · 91

Acknowledgments

The Advanced Energy Design Guide for Small Warehouses and Self-Storage Buildings is the fourth in a series of Guides that address building types that represent major energy users in the commercial building stock. A huge debt of gratitude is extended to the authors of the previous Guides because they paved the way and defined the basic structure, content, and format of the books as well as the procedures for the reporting and the reviews. Following in their footsteps has provided consistency among these two Guides in addition to being a tremendous time saver. Building upon the previous work also allowed the Project Committee to finish its work in a very short period of time.

Continuity with the previous Guides was further maintained because many of the same organizational partners were involved, as were many of the project committee members as well. ASHRAE was again the lead organization, with full support from the American Institute of Architects (AIA), the Illuminating Engineering Society of North America (IESNA), the United States Department of Energy (DOE) and the United States Green Building Council (USGBC). Individuals from each of these organizations served as members of the Steering Committee under the leadership of 2002–2003 ASHRAE President Don Colliver. Their contributions were significant in terms of the direction and oversight they provided to the ASHRAE Special Project 114 Committee (SP-114).

Members on the project committee came from the partner organizations, ASHRAE Standing Standards Project Committee 90.1 (SSPC 90.1), several ASHRAE Technical Committees, and the Metal Building Manufacturers Association. These members served not only on the project committee but also as liaisons to their respective organizations where they coordinated the multiple technical reviews. This group of project committee members consisted of mostly veterans of previous Guides and demonstrated what can be accomplished when people have a good working relationship and are given a very short timeline to complete a very large task. From the first organizational meeting in late March 2007 to the final document approval in September 2007, these folks remained focused and dedicated to the task at hand.

In addition to the voting members on the committee, there were a number of other individuals who contributed to the success of this Guide. The specific individuals and their contributions were: Bing Liu and Wei Jiang of the Pacific Northwest National for the simulation runs and results; Lilas Pratt of ASHRAE for her assistance, organiza-

tional skills, and dedication to the project as well as serving as a gracious host at all the meetings at ASHRAE Headquarters; and Cindy Sheffield Michaels of ASHRAE for the editing and layout of the book. This Guide could not have been developed without all of their contributions.

I am very proud of the Guide that the project committee developed and am amazed at the accomplishment in such a short time period. Each project committee member as well should be proud of their individual contributions to this most worthwhile document.

Ronald E. Jarnagin
SP-114 Chair
January 2008

Abbreviations and Acronyms

A	=	area, ft ²
ACCA	=	Air Conditioning Contractors of America
AEDG-WHSE	=	<i>Advanced Energy Design Guide for Small Warehouses and Self-Storage Buildings</i>
AFUE	=	annual fuel utilization efficiency, dimensionless
AIA	=	American Institute of Architects
ASHRAE	=	American Society of Heating, Refrigerating and Air-Conditioning Engineers
ASTM	=	American Society for Testing and Materials
ANSI	=	American National Standards Institute
Btu	=	British thermal unit
CA	=	census area
c.i.	=	continuous insulation
Cx	=	commissioning
CxA	=	commissioning authority
cfm	=	cubic feet per minute
COP	=	coefficient of performance, dimensionless
CRI	=	Color Rendering Index
CRRC	=	Cool Roof Rating Council
D	=	diameter, ft
DL	=	<i>Advanced Energy Design Guide</i> code for “daylighting”
DOE	=	U.S. Department of Energy
E_c	=	efficiency (combustion), dimensionless
E_t	=	efficiency (thermal), dimensionless
EER	=	energy efficiency ratio, Btu/W·h
EF	=	energy factor
EIA	=	Energy Information Administration
EL	=	<i>Advanced Energy Design Guide</i> code for “electric lighting”
EN	=	<i>Advanced Energy Design Guide</i> code for “envelope”

ERV	= energy recovery ventilator
EX	= <i>Advanced Energy Design Guide</i> code for “exterior lighting”
F	= slab edge heat loss coefficient per foot of perimeter, Btu/h·ft·°F
GC	= general contractor
Guide	= <i>Advanced Energy Design Guide for Small Warehouses and Self-Storage Buildings</i>
HC	= heat capacity, Btu/ft ² ·°F
HID	= high-intensity discharge
HSPF	= heating season performance factor, Btu/W·h
HV	= <i>Advanced Energy Design Guide</i> code for “HVAC systems and equipment”
HVAC	= heating, ventilating, and air-conditioning
IESNA	= Illuminating Engineering Society of North America
in.	= inch
IPLV	= integrated part-load value, dimensionless
kBtuh	= thousands of British thermal units per hour
kW	= kilowatt
LBNL	= Lawrence Berkeley National Laboratory
LPD	= lighting power density, W/ft ²
ls	= linear systems
MBMA	= Metal Building Manufacturers Association
N/A	= not applicable
NEMA	= National Electrical Manufacturers Association
NFRC	= National Fenestration Rating Council
NREL	= National Renewable Energy Laboratory
NZEB	= net zero energy buildings
O&M	= operation and maintenance
OPR	= Owner’s Project Requirements
PF	= projection factor, dimensionless
PL	= <i>Advanced Energy Design Guide</i> code for “plug loads”
ppm	= parts per million
psf	= pounds per square foot
QA	= quality assurance
R	= thermal resistance, h·ft ² ·°F/Btu
SEER	= seasonal energy efficiency ratio, Btu/W·h
SHGC	= solar heat gain coefficient, dimensionless
SRI	= Solar Reflectance Index, dimensionless
SSPC	= standing standards project committee
SWH	= service water heating
TAB	= test and balance
TC	= technical committee
U	= thermal transmittance, Btu/h·ft ² ·°F
USGBC	= U.S. Green Building Council
VAV	= variable air volume
VC	= <i>Advanced Energy Design Guide</i> code for “ventilation control”
VLT	= visible light transmittance
W	= watts
w.c.	= water column
wg	= water gauge
WH	= <i>Advanced Energy Design Guide</i> code for “water heating systems and equipment”

Introduction

1

The *Advanced Energy Design Guide for Small Warehouses and Self-Storage Buildings* (AEDG-WHSE; the Guide) is intended to provide a simple approach for contractors and designers who create warehouses. Application of the recommendations in the Guide should result in warehouses with 30% energy savings when compared to those same warehouses designed to the minimum requirements of *ANSI/ASHRAE/IESNA Standard 90.1-1999, Energy Standard for Buildings Except Low-Rise Residential Buildings*. This document contains recommendations and is *not* a minimum code or standard. It is intended to be used in addition to existing codes and standards and is not intended to circumvent them. This Guide represents *a way*, but *not the only way*, to build energy-efficient warehouses that use significantly less energy than those built to minimum code requirements. The recommendations in this Guide provide benefits for the owner while maintaining quality and functionality of the space.

This Guide has been developed by a committee representing a diverse group of energy professionals drawn from the American Society of Heating, Refrigerating and Air-Conditioning Engineers (ASHRAE), the American Institute of Architects (AIA), the U.S. Green Building Council (USGBC), the Metal Buildings Manufacturers Association (MBMA), and the Illuminating Engineering Society of North America (IESNA). To quantify the expected energy savings, these professionals selected potential envelope, lighting, HVAC, and service water heating (SWH) energy-saving measures for analysis. These included products that were deemed to be both practical and commercially available. Although some of the products may be considered premium, products of similar performance are available from multiple manufacturers. Each set of measures was simulated using an hourly energy analysis program for two warehouse prototype buildings in representative cities in various climates. Simulations were run for reference buildings (buildings designed to ASHRAE/IESNA Standard 90.1-1999 criteria) compared to buildings built using recommendations contained in this Guide to determine whether the expected 30% savings target was achieved. The analysis showed an average energy savings of 42% from the ASHRAE/IESNA Standard 90.1-1999 baseline.

The scope of this Guide covers warehouses up to 50,000 ft² and self-storage buildings that use unitary heating and air-conditioning equipment. Buildings of this type with

these HVAC system configurations represent a significant amount of commercial warehouse space in the United States. This Guide provides straightforward recommendations and how-to tips to facilitate its use by anyone in the construction process who wants to produce more energy-efficient buildings.

In general, this Guide addresses typical warehouse types, including both self-storage and nonrefrigerated warehouses. The Guide *excludes* certain warehouses, such as refrigerated warehouses and warehouses that are unheated. Also excluded from the Guide are “built-up” HVAC systems using chillers and chilled-water systems. The Guide is primarily intended for new construction, but it may also be applicable to renovation, remodeling, and modernization projects.

As an added value for designers and contractors, this Guide features case study examples of energy-efficient buildings. The case studies demonstrate that effectively addressing environmental challenges can also result in the creation of good, often excellent, architecture. The case studies illustrate how energy considerations have been incorporated in various design strategies and techniques. However, the example buildings may incorporate additional features that go beyond the scope of the recommendations of the Guide.

It is hoped that the Guide will result in a more sustainable environment for society. The energy savings target of 30% is the first step in the process toward achieving a net zero energy building (NZEB), which is defined as a building that, on an annual basis, draws from outside sources equal or less energy than it provides using on-site, renewable energy sources. ASHRAE/IESNA Standard 90.1-1999, the energy conservation standard published at the turn of the millennium, provides the fixed reference point for all the Guides in this series. The primary reason for this choice as the reference point is to maintain a consistent baseline and scale for all the 30% AEDG series documents. A shifting baseline between multiple documents in the AEDG series would lead to confusion among users about the level of energy savings achieved. However, it is interesting to see what the energy savings of the Guide would be relative to ASHRAE/IESNA Standard 90.1-2004, which has reduced the lighting power densities and improved efficiency levels for the cooling equipment. Using ASHRAE/IESNA Standard 90.1-2004 as the basis, the recommendations in this Guide would produce an average energy savings of 33%.

Plans are in place for development of additional AEDG documents in this decade that will assist users in achieving 50% and 70% energy-saving levels as milestones toward the NZEB goal. The ultimate goal of the participating organizations is to assist in the design and construction of NZEBs.

CONTENTS

Chapter 2 of this Guide contains a chart that walks the user through the design process of applying the recommendations in this Guide, while Chapter 3 provides the actual recommendations for a way to meet the 30% energy savings goal. Chapter 3 includes eight recommendation tables, which are broken down by building component and organized by climate according to the eight climate zones (and specific counties within each climate zone) identified by the U.S. Department of Energy (DOE). The user should note that the recommendation tables do not include all of the components listed in ASHRAE/IESNA Standard 90.1-1999 since the Guide focuses only on the primary energy systems within a building. Chapter 4 provides case studies of actual energy-efficient buildings and systems. Chapter 5 provides essential guidance in the form of concise how-to tips to help the user understand and apply the recommendations from this Guide. Additional “bonus savings” strategies are also found in Chapter 5. Three appendices are included for reference. Appendix A provides thermal performance factors for alternate opaque envelope construction. Appendix B provides climate zone information for a variety of locations in Mexico and Canada. Appendix C provides a list of additional resources.

This Guide includes specific recommendations for energy-efficient improvements in the following technical areas to meet the 30% energy savings goal:

- Building Envelope
 - Roofs
 - Walls
 - Slabs
 - Doors
 - Vertical Glazing
 - Skylights
- Lighting
 - Daylighting
 - Interior Electric Lighting
 - Lighting Controls
- HVAC Equipment and Systems
 - Cooling Equipment Efficiencies
 - Heating Equipment Efficiencies
 - Supply Fans
 - Ventilation Control
 - Ducts
- Service Water Heating
 - Equipment Efficiencies
 - Pipe Insulation

In addition, “bonus savings” strategies to improve energy efficiency beyond the 30% energy savings level are included for:

- Exterior Façade Lighting
- Plug Loads

Quality assurance (QA) and commissioning (Cx) are also covered in Chapter 5.

HOW TO USE THIS GUIDE

There are numerous ways to use this Guide effectively that are consistent with the background and knowledge of the user—some may turn immediately to the climate-specific recommendations; others may choose to first understand how energy goals fit into the design process. In addition, this Guide provides recommendations that would assist the user in achieving energy efficiency credits for LEED® or other building energy rating systems. The authors of this Guide suggest the following approach:

- Review Chapter 2 to understand how energy efficiency goals relate to the stages of building design. The flow charts, tables, and checklists in Chapter 2 can be used to lead, communicate, and manage the design and construction of energy-efficient buildings.
- Review Chapter 3 for specific recommendations to achieve the 30% energy savings level in your climate zone. These criteria provide *a way* to achieve the 30% savings goal and also serve as a starting point to further refine the energy design. The authors realize that designers typically don’t receive sufficient design fees to perform energy design optimization. Therefore, the contents of this chapter can serve as a starting point to meet specific requirements of a particular project.
- Review the Chapter 4 case studies to assure you and your team that other designers and builders have successfully used these and similar techniques to build energy-

efficient buildings in the real world. Most of the case study buildings have won awards or achieved peer recognition for their energy efficiency attributes.

- Use Chapter 5 to detail how the Chapter 3 recommendations are applied. Use the how-to tips, cross-referenced to the recommendation tables, to apply best practices (as well as cautions to avoid known problems in energy-efficient construction) to the specific circumstances of your project. Also, consider the recommendations for “bonus savings.”

Integrated Process for Achieving Energy Savings

2

This chapter of the AEDG-WHSE provides resources for those who want to understand and adopt an overall *process* for designing, constructing, and operating energy-efficient warehouse buildings. The resources listed below are above and beyond the straightforward presentation of recommendations in Chapter 3 and the how-to tips in Chapter 5 that lead to energy savings of 30% beyond ASHRAE/IESNA Standard 90.1-1999. The resources are:

- *A narrative discussion of the design and construction process that points out the opportunities for energy savings in each phase.* It further explains the steps that each team member or discipline should take to identify and implement energy savings concepts and strategies. It also includes a discussion on how the quality assurance (QA) measures are worked into the process at each phase and how some of these measures can be used by the owner to maintain energy performance for the life of the facility.
- *A reference table or matrix that leads the Guide's user through the process of identifying and selecting energy-saving measures to meet major energy design goals.* This information is presented in Table 2-5, which ties together detailed strategies, recommendations for meeting the 30% energy use reduction target, and related how-to information.

The following presentation of an integrated process for achieving energy savings in warehouse buildings is valuable for designers and builders who want to augment and improve their practices so that energy efficiency is deliberately considered at each stage of the development process from project conception through building operation. Commissioning (Cx) begins in the early stage of design and continues through operation and is an integral part of each phase. These stages are shown in Figure 2-1.

The key benefits of following this integrated process include:

- Understanding the specific step-by-step activities that owners, designers, and construction team members need to follow in each phase of the project's delivery, including communication of management, design, construction, QA, Cx, operation and maintenance (O&M), and occupancy functional requirements an owner should follow to maintain the specified energy performance of the facility.



Figure 2-1. Stages of design.

- Identifying energy efficiency goals and selecting design strategies to achieve those goals.
- Incorporating QA, including building Cx procedures, into the building design and delivery process to ensure that energy savings of recommended strategies are actually achieved and that specific documentation needed to maintain energy performance is provided to the owner.
- Owner understanding of the ongoing activities needed to help ensure continued energy performance for the life of the facility, resulting in lower total cost of ownership.

Users of this Guide who follow the recommended process in their design and construction practice will benefit from achieving the goals of enhanced energy savings.

1. DESIGN (INCLUDING PLANNING AND PRE-DESIGN)

Documentation of the adopted energy goals and general strategies begin in the design phase. In a warehouse, this typically involves identifying and documenting the objectives and criteria for the warehouse project that form the Owner’s Project Requirements (OPR), a brief, two-page description that includes the project’s energy and sustainable development goals (see QA3 in Chapter 5). The OPR guides the team and provides a guide to be used during the design, construction, and operation of the project.

This Guide emphasizes goals that relate to the energy uses that can produce the largest savings. Achieving energy efficiency in warehouses is based on a combination of strategies that include higher building envelope insulation and glazing, lower lighting power densities (LPDs) through more efficient lighting design, use of natural daylight to reduce the need for electric lighting and associated daylighting controls, and higher-efficiency heating and air-conditioning systems. Warehouses are used in a wide variety of configurations and typically have some office area. The AEDG-WHSE uses the *Advanced Energy Design Guide for Small Office Buildings* (AEDG-SO) to establish the recommendations for the office portion of the warehouse. To assist users of this Guide, pertinent information from the AEDG-SO is included within the AEDG-WHSE.

Interior lighting plays a major role in warehouse energy use. Both ASHRAE/IESNA Standard 90.1-1999 and this Guide recognize differences between lighting requirements for bulk storage, fine storage, and office space. ASHRAE/IESNA Standard 90.1-1999 specifies LPDs for general medium/bulky storage, fine storage, and office lighting; this Guide specifies lower LPDs for these three areas.

In addition to lighting, differences in building application, climate, and even orientation will impact the selection of various energy goals and strategies. As an example, Figures 2-2 and 2-3 show energy use mixes for warehouses located in a hot, dry climate (Phoenix) and a cold climate (Chicago). These figures demonstrate that cooling and lighting energy predominates in Phoenix; thus, in that climate zone, the goals and strategies relating to cooling and lighting should receive the highest priority. Conversely, in Chicago, the goals and strategies relating to heating and lighting should receive the highest priority. Also, in the “Bonus Savings” section of Chapter 5, specific examples provide methods to achieve savings above the Chapter 3 requirements.

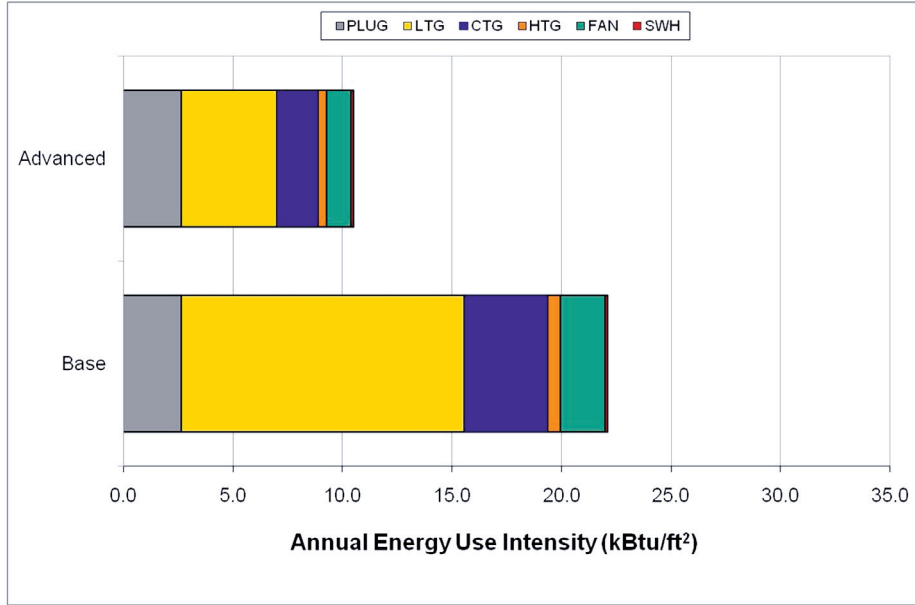

Figure 2-2. Warehouse energy use in Phoenix.

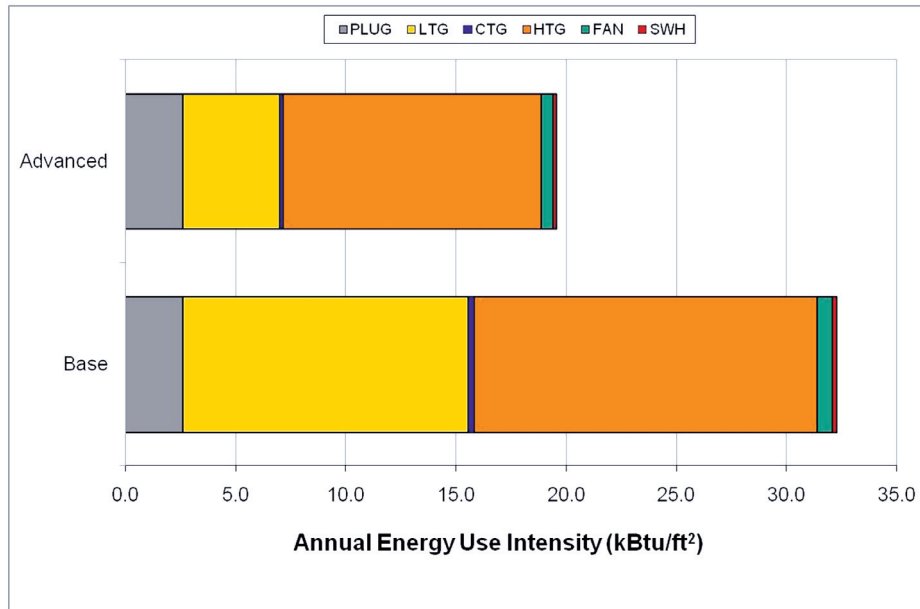

Figure 2-3. Warehouse energy use in Chicago.

In the design phase, the team integrates the energy goals into building plans, sections, details, and specifications. The sequence of many design decisions, such as building and glazing orientation as well as other strategies identified in this chapter, has a major impact on energy efficiency. These decisions must, therefore, be made much sooner in the process than is typically done. The steps listed in Table 2-1, presented in sequence, identify the appropriate time in the process to apply specific recommendations from this Guide.

Table 2-1. Energy Goals in the Context of the Design Phase

A typical “integrated” design process includes the following steps in sequence, with energy-related actions flagged (*).

Activities	Responsibilities	Where to Find Information
1. Select Team a. Design Team b. QA Provider c. Construction Team	Owner evaluates potential service providers and selects team.	Chapter 5, QA1 and QA2
2. Owner’s Project Requirements (OPR) ^a * a. Choose Recommendation Table Items b. Codes/Standards Requirements	Owner and CxA define the OPR and goals.	Chapter 2, Table 2-5 ^b Chapter 3
3. Define Budget a. Develop and Review Design Budget b. Develop and Review Construction Budget c. Develop and Review QA Budget	Owner, GC, Designer Owner, Designer Owner, GC, Estimator Owner, CxA	Chapter 5, QA4
4. Select Implementation Recommendations * a. Specify System Preferences b. Update OPR c. Check for Rebate/Incentive Programs	Owner, Designer, GC	Chapter 5, QA3 Chapter 3
5. Develop Design and Construction Schedule	Owner, GC, Designer	Chapter 5, QA5
6. Design Development * a. Develop Building Plans, Sections, and Details Incorporating above Strategies b. Determine Ventilation Requirements c. Develop HVAC Load Calculations d. Size HVAC Equipment e. Integrate QA Specifications into Project Manual f. Specify ENERGY STAR [®] Appliances	Designer, CxA	Chapter 5
7. Construction Documents a. Develop Lighting and Equipment Details b. Develop Outdoor Air Management Details	Owner, Designer	Chapter 5, Lighting Chapter 5, Outdoor Air
8. Design Review * — Verify That Project Meets Original Goals	Owner, Designer, CxA, GC	Chapter 3 Chapter 5
9. Perform Final Coordination and Integration of Architectural, Mechanical, and Electrical Systems	Designer	Chapter 3 Chapter 5
10. Perform Final Cost Estimates	GC, Estimator	
11. Review Final Design Documents	Owner, Designer, CxA	Chapter 3 Chapter 5, QA6

a. The OPR is a written document that details the intent for energy efficiency, measurable performance criteria, sustainability, functional requirements, and the expectations of how the facility will be used and operated. See Chapter 3 for specific recommendations for each of the building components. Lists of implementation examples are provided in Chapter 5.

b. Table 2-5 presents four goals along with specific strategies for achieving energy savings in warehouse construction. Reducing loads (Goal 1), both internal and external, is the most basic. Matching the capacity of energy-using systems to the reduced loads (Goal 2) is also important. Oversized systems cost more and do not operate at their optimum efficiency. Higher-efficiency equipment (Goal 3) will use less energy to meet any given load. Thus, high-efficiency equipment, in systems whose capacity matches peak loads, serving a building designed and constructed to the lowest practical loads, will result in the lowest energy use and cost. And finally, Goal 4 addresses the integration of building systems to increase energy savings potential.

QUALITY ASSURANCE: IN-HOUSE OR THIRD PARTY?

Users of this Guide may debate whether to use in-house staff or outside third parties as the Commissioning Authority (CxA) to perform the quality assurance (QA) tasks in the design, construction, and acceptance phases of the project. A case can be made for either approach depending on project budget, design complexity, capabilities of the design and construction team, and availability of local Cx expertise.

While both approaches can be effective, building owners should insist that the QA tasks be carried out by a party who is independent from the design and construction team, especially if complex and critical systems are installed. Independent review ensures that “fresh eyes” are applied to energy performance QA.

Where the in-house approach is deemed to be in the best interests of the building owner, the QA tasks are best accomplished by personnel with no direct interest in the project. For example, qualified staff working on other projects could be assigned as disinterested parties to check and verify the work of their colleagues. However, building owners can expect to get the most independent QA review from outside third parties. Indeed, most of the literature on building Cx and energy performance QA recommends or requires independent outside reviews. In either case, building owners should expect to bear the cost of approximately 12–50 professional staff hours to carry out the Suggested Commissioning Scope (see next page) depending on project specifics. Additional information can be found in Chapter 5.

Quality Assurance: Prior to design, an OPR should be developed that documents the owner’s objectives and criteria for the project in pre-programming. Combined with programming, the OPR provides the design team the guidance needed to successfully meet the needs of the owner. During the design process, the design team documents its design assumptions (Basis of Design) and includes them in the OPR. A party other than the installing contractor, architect, or engineer of record should review the contract document and verify that it incorporates the OPR and the associated strategies contained in this Guide before the start of construction. The owner’s agent, if qualified, can provide the required review. This review, along with subsequent inspection, testing, and reporting, is referred to as *commissioning*. The Commissioning Process is a quality-oriented process for achieving, verifying, and documenting that the performance of facilities, systems, and assemblies meets defined objectives and criteria.

The reviewer provides the owner and designers with written comments outlining where items do not comply with these defined objectives and criteria selected from this Guide. Comments should be resolved and any required changes should be completed before start of construction. The owner may choose to use an outside third party to perform this review.

Once the design phase is completed, the party that is independent of the design and construction team fulfills the QA role to ensure that the goals, strategies, and recommendations are actually installed and achieved. This Guide provides recommendations to ensure that the goals, strategies, and actions selected are properly executed during the later stages of the building life cycle in Chapter 4 under “Quality Assurance.”

SUGGESTED COMMISSIONING SCOPE

- Review the OPR and the designers' basis-of-design documentation for completeness and clarity. The information provided by the design team for review should include project and design goals, measurable performance criteria, budgets, schedules, success criteria, and supporting information.
- Develop project-specific commissioning/quality assurance (Cx/QA) specifications and construction checklists for building envelope and lighting, mechanical, and plumbing systems that will be verified during the delivery of the project. The specifications will incorporate Cx/QA activities into the construction process and, with the accompanying construction checklists, provide a clear understanding to all participants of their specific roles, responsibilities, and effort. The Guide specifications will be reviewed, modified, and blended into the construction documents by the designers.
- Conduct one design review of the construction documents before 100% completion. A review before construction document completion (around 90% completion recommended) allows any changes to be incorporated. The review will focus on ensuring the design is consistent with the OPR and that all construction requirements are clear and well coordinated. It is also intended to ensure that the specifications describe the roles and responsibilities of all parties to the Cx process so that contractors have a clear understanding of their responsibilities. Prepare a report identifying concerns and opportunities, and use it in working with the owner and designers to develop a collaborative partnership that will ensure the building performs as intended. Provide a report that tracks issues to resolution and follow a collaborative process to facilitate resolution.
- Conduct one meeting or teleconference to discuss review comments and, if necessary, to adjudicate issues with the design team using owner input, and issue a final report illustrating the disposition of each issue raised. Use the report to verify during construction site visits that issues were corrected.
- If a pre-bid meeting is held with bidding contractors, participate in it to emphasize the inclusion of Cx and describe the Cx process for the specific project.
- Conduct a brief meeting with the project team reviewing QA procedures, roles, and responsibilities and establishing a tentative schedule of Cx/QA activities.
- Review submittal information for systems being commissioned and provide appropriate comments to team and owner for action. Based on the submittal information, develop test procedures that will be used to verify system performance and distribute to the team.
- Conduct two site visits: one during construction to observe construction techniques and to identify issues that may affect performance and one after construction is completed to verify identified issues/concerns were resolved. Review issues with appropriate team members at the end of each site visit in accordance with established communication protocols and issue one report per visit documenting findings. Establish and maintain an issues log for tracking issues identified.
- Direct and witness testing and document results. Issues identified will be documented in the issues log and tracked to resolution. General contractor (GC) will schedule testing activities and ensure that responsible parties needed for verification are present.
- Review O&M information to ensure warranty requirements and preventive maintenance information required are part of the documentation along with a copy of the OPR and basis-of-design information.
- Witness training of O&M staff to help ensure that O&M staff understands the systems and their operation, warranty responsibilities, and preventive maintenance requirements.

2. CONSTRUCTION

The best designs yield the expected energy savings when the construction plans and specifications are correctly designed and executed. This section outlines what actions the project team can perform to assist in meeting the energy goals. (See Table 2-2 to identify the appropriate time in the process to apply specific recommendations from this Guide.)

During construction, the independent CxA conducts submittal reviews and site visits to verify the construction of the building envelope, HVAC system, and lighting system meet the objectives and criteria documented in the OPR. The purposes of these site visits are as follows:

- **Observations for Operability and Maintainability.** Participate in an ongoing review of the building envelope, mechanical systems, and lighting systems. Prepare field notes and deficiency lists and distribute to the owner, designer, and general contractor (GC).
- **Verify Access Requirements.** Review shop drawings and perform construction observations to verify that the required access to systems and equipment has been provided.
- **Random Spot Verification.** Randomly verify installation checklists completed by contractors.

A written report on the site visit that documents issues requiring resolution by the design and/or construction team should be provided. The estimated level effort for the CxA's written report is two to four hours during the construction phase for the size of warehouse buildings covered by this Guide.

3. ACCEPTANCE

At this final stage of construction, the project team and the independent CxA verify that systems are operating as intended, HVAC system airflows are within the design parameters, and daylight harvesting controls are calibrated and operating correctly. When the team is satisfied that all systems are performing as intended, the QA effort of the design and construction team is complete. (See Table 2-3 to identify the appropriate time in the process to apply specific recommendations from this Guide.)

4. OCCUPANCY

During the first year of operation, the building owner needs to review the overall operation and performance of the building. Building systems not performing as expected should be discussed with the design and construction team with issues resolved during the warranty period. The CxA may be brought in to help resolve any Cx/warranty issues. (See Table 2-4 to identify the appropriate time in the process to apply specific recommendations from this Guide.)

5. OPERATION

Energy use and additions of energy-consuming equipment need to be documented and compared against previous data to determine if the building and its systems are operating at peak performance for the life of the building. The CxA needs to provide the ongoing method for monitoring the energy consumption of the building.

Reducing the actual energy use of warehouse buildings will be enhanced when advisory energy-tracking information is conveyed to the owner or owner's staff as part of the design package. This information should be developed in simple language and format. This will allow the end-user to track and benchmark the facility's utility bills and take corrective action to maintain the intended efficiency of the original design. This ongoing Cx will require some additional cost but will typically save substantially more by preventing efficiency degradation in the facilities' energy systems. Additional information on energy-effective operation and ongoing energy management is available in *ASHRAE Handbook—HVAC Applications*.

Table 2-2. Energy Goals in the Context of the Bidding and Construction Process

Activities	Responsibilities	Where to Find Information
1. Pre-Bid Conference Discuss importance of energy systems to contractors/subcontractors Define quality control/Cx role	Owner, Designer, CxA, GC	Chapter 5, QA7
2. Progress Meetings Regular updates on energy-efficiency-related measures Scheduling/update QA	Owner, Designer, GC	
3. Envelope/Energy Systems QA QA building envelope construction QA HVAC systems QA lighting systems	CxA	Chapter 5, QA8 and QA9

Table 2-3. Energy Goals in the Context of the Acceptance Phase

Activities	Responsibilities	Where to Find Information
1. Assemble punch list of required items to be completed	GC	
2. Performance testing, as required of GC and subcontractors	GC, Subcontractors	Chapter 5, QA10
3. Building is identified as substantially complete	Owner, Designer, CxA	Chapter 5, QA11
4. Maintenance manual submitted and accepted	Owner, Designer, CxA	Chapter 5, QA12
5. Resolve quality control issues identified throughout the construction phase	Owner, Designer, CxA	Chapter 5, QA13
6. Final acceptance	Owner, Designer	Chapter 5, QA14

Table 2-4. Energy Goals in the Context of the Occupancy Phase

Activities	Responsibilities	Where to Find Information
1. Establish building maintenance program	Owner and staff, CxA	Chapter 5, QA15
2. Create post-occupancy punch list	Owner and staff	
3. Monitor post-occupancy performance	Owner and CxA	Chapter 5, QA16

ENERGY GOALS AND STRATEGIES

The goals listed in Table 2-5, provide detailed strategies and recommendations to meet the 30% energy use reduction target. The related how-to information in this Guide identifies selected energy-saving measures to meet major energy design goals.

Table 2-5. Energy Goals and Strategies

Prioritize Goals	General Strategies	Detailed Strategies	Recommendations (see Chapter 3)	How-To Tips (see Chapter 5)
Goal 1. Reduce loads on energy-using systems				
Reduce internal loads	Equipment and Appliances: Reduce both cooling loads and energy use	Use more efficient equipment and appliances	Use low-energy computers and monitors; use ENERGY STAR® equipment	PL1–3
		Use controls to minimize usage and waste	Turn off or use “sleep mode” on computers, monitors, copiers, and other equipment	PL3
		Educate building staff	Provide training, brochures, and other material to encourage energy efficiency	EL5, DL1, 2, 9
	Lighting: Reduce both cooling loads and energy use	Maximize the benefits of daylighting	Vertical glazing, skylights, interior lighting	EN26, 29, 32–44, DL1–13
		Use skylights and north-facing clerestories to daylight interior zones	Skylights and vertical glazing	DL7
		Use efficient electric lighting system	Interior lighting	EL1–26
		Use separate controls for lighting in areas near windows	Interior lighting	DL1–2, 9–12, EL5, 7–8
		Use automatic controls to turn off lights when not in use	Interior lighting	DL 2, EL5, 7–8
	Reduce heat gain/loss through building envelope	Building Envelope: Control solar gain to reduce cooling load through windows	Use beneficial building form and orientation	
Minimize windows east and west, maximize north and south			Vertical glazing	EN26, 29
Use glazing with low solar heat gain coefficient (SHGC)			Vertical glazing, skylights	EN22–24, 27, 31–32
External shade glazing to reduce solar heat gain and glare			Vertical glazing	EN24

Table 2-5. Energy Goals and Strategies (Continued)

Prioritize Goals	General Strategies	Detailed Strategies	Recommendations (see Chapter 3)	How-To Tips (see Chapter 5)
Reduce heat gain/loss through building envelope (continued)	Control solar gain to reduce cooling load through windows	Use vegetation on S/E/W to control solar heat gain (and glare)	Vertical glazing	EN28
	Reduce solar gain through opaque surfaces to reduce cooling load	Increase insulation of opaque surfaces	Roofs, walls, floors, doors	EN2–20
		Increase roof surface reflectance and emittance	Roofs	EN1
		Shade building surfaces with deciduous or coniferous trees as appropriate for surface orientation		
	Reduce conductive heat gain and loss through building envelope	Increase insulation on roof, walls, floor, slabs, and doors and decrease window U-factor	Roofs, walls, floors, doors, vertical glazing	EN2–20
	Reduce air infiltration	Provide continuous air barrier		
	Reduce heat gain or loss from ventilation exhaust air	Use energy recovery to precondition outdoor air	Energy recovery	
Reduce thermal loads	Utilize passive solar designs	Use thermal storage, trombe walls, interior mass		EN30
Reduce HVAC loads	Reduce heat gain and loss in ductwork	Insulate ductwork	HVAC	HV10
		No ductwork outside the building conditioned space	HVAC	HV9
Refine building to suit local conditions	Consider natural ventilation, highest potential in marine climates, high potential in dry climates	Operable windows with screens so that air conditioning and heating are not necessary during transition periods	Vertical glazing	EN27
		For buildings with operable windows, design building layout for effective cross-ventilation	Vertical glazing	EN27

Table 2-5. Energy Goals and Strategies (Continued)

Prioritize Goals	General Strategies	Detailed Strategies	Recommendations (see Chapter 3)	How-To Tips (see Chapter 5)
Goal 2. Size HVAC systems for reduced loads				
Properly size equipment	Calculate load		HVAC	HV3
	Size equipment		HVAC	HV1, 2, 4
Goal 3. Use more efficient systems				
Use more efficient HVAC systems	Select efficient cooling equipment	Meet or exceed listed equipment efficiencies in “Recommendations” chapter	HVAC	HV1, 2, 4, 6, 17
		Meet or exceed listed part-load performances in “Recommendations” chapter	HVAC	HV1, 2, 4, 6, 21
	Select efficient heating equipment	Meet or exceed listed equipment efficiencies in “Recommendations” chapter	HVAC	HV1, 2, 6, 16, 20
	Select efficient energy recovery equipment	Meet or exceed listed equipment efficiencies in “Recommendations” chapter		HV5, 17
Improve outdoor air ventilation	Control outdoor air dampers	Use air economizer		HV7, 14
		Use demand-controlled ventilation (where appropriate)	Ventilation	HV7, 14, 22
		Shut off outdoor air and exhaust air dampers during unoccupied periods	Ventilation	HV7, 8, 14
Improve fan power	Design efficient duct distribution system	Minimize duct and fitting losses	Ducts	HV9, 18, 19
	Reduce duct leakage	Seal all duct joints and seams	Ducts	HV11
	Select efficient motors	Use high-efficiency motors		HV12

Table 2-5. Energy Goals and Strategies (Continued)

Prioritize Goals	General Strategies	Detailed Strategies	Recommendations (see Chapter 3)	How-To Tips (see Chapter 5)
Improve HVAC controls	Use control strategies that reduce energy use	Divide building into thermal zones	HVAC	HV13, 21
		Use time-of-day scheduling, temperature setback and setup, pre-occupancy purge	HVAC	HV14
Ensure proper air distribution	Test, adjust, and balance the air distribution system	Use industry-accepted procedures	HVAC	HV7, 15, 22
Use more efficient service water heating systems	Select efficient service water heating equipment	Meet or exceed listed equipment efficiencies in “Recommendations” chapter	SWH	WH1–4, 7–8
	Minimize distribution losses	Use point-of-use units	SWH	WH1–2, 7–8
		Minimize pipe distribution	SWH	WH5
		Insulate piping	SWH	WH6
Use more efficient lighting	More efficient interior lighting	Do not use incandescent lighting unless it will be used infrequently. Avoid incandescent sources except for specific task requirements.		EL27
		Use more efficient electric lighting system	More efficient lamps, ballasts, ceiling fixtures, and task lights	EL7–12
	More efficient exterior lighting	Use more efficient electric lighting systems	More efficient exterior lighting sources	EX2
Goal 4. Refine systems integration				
Integrate building systems	Integrate systems—high-efficiency adv. case			EN23, DL8, 13, QA1
	Integrate systems—daylight adv. case		Advanced daylighting option	EN23, DL8, 13, QA1

Recommendations by Climate

3

Users should determine the recommendations for their construction project by first locating the correct climate zone. The U.S. Department of Energy (DOE) has identified eight climate zones for the United States, with each defined by county borders, as shown in Figure 3-1. This Guide uses these DOE climate zones in defining energy recommendations that vary by climate. Tables with climate zones identified for a variety of locations in Canada and Mexico are provided in Appendix B.

This chapter contains a unique set of energy-efficient recommendations for each climate zone. The recommendation tables represent *a way*, but *not the only way*, for reaching the 30% energy savings target over ASHRAE/IESNA Standard 90.1-1999. Other approaches may also save energy, but they are not part of the scope of this Guide; assurance of those savings is left to the user. The user should note that the recommendation tables do not include all of the components listed in ASHRAE/IESNA Standard 90.1 since the Guide focuses only on the primary energy systems within a building.

When a recommendation is provided, the recommended value differs from the requirements in ASHRAE/IESNA Standard 90.1-1999. When “No recommendation” is indicated, the user must meet at least the minimum requirements of ASHRAE/IESNA Standard 90.1-1999 or the requirements of local codes whenever they exceed the requirements of ASHRAE/IESNA Standard 90.1-1999.

Each of the climate zone recommendation tables includes a set of common items arranged by building subsystem: envelope, lighting, HVAC, and service water heating (SWH). Recommendations are included for each item, or subsystem, by component within that subsystem. For some subsystems, recommendations depend on the construction type. For example, insulation values are given for mass, metal building, and steel-framed and wood-framed wall types. For other subsystems, recommendations are given

BONUS SAVINGS

Chapter 5 provides additional recommendations and strategies for savings for plug loads and exterior lighting over and above the 30% savings recommendations contained in the following eight climate regions.

for each subsystem attribute. For example, vertical glazing recommendations are given for thermal transmittance, solar heat gain coefficient (SHGC), and exterior sun control.

The fourth column in each table lists references to how-to tips for implementing the recommended criteria. The tips are found in Chapter 5 under separate sections coded for envelope (EN), daylighting (DL), electric lighting (EL), HVAC systems and equipment (HV), and service water heating systems and equipment (WH) suggestions. Besides how-to tips for design and maintenance suggestions that represent good practice, these tips include cautions for what to avoid. Important QA considerations and recommendations are also given for the building design, construction, and post-occupancy phases. Note that each tip is tied to the applicable climate zone in Chapter 5. The final column is provided as a simple checklist to identify the recommendations being used for a specific building design and construction.

The recommendations presented are either minimum, maximum, or specific values (which are both the minimum and maximum values). Minimum values include R-values, mean lumens/watt, SEER, SRI, EER, IPLV, AFUE, E_c , HSPF, COP, E_t , EF, VLT, and insulation thicknesses. Maximum values include U-factors, SHGC, area, LPD, and friction rate. Specific values include skylights/area (percent of gross roof).

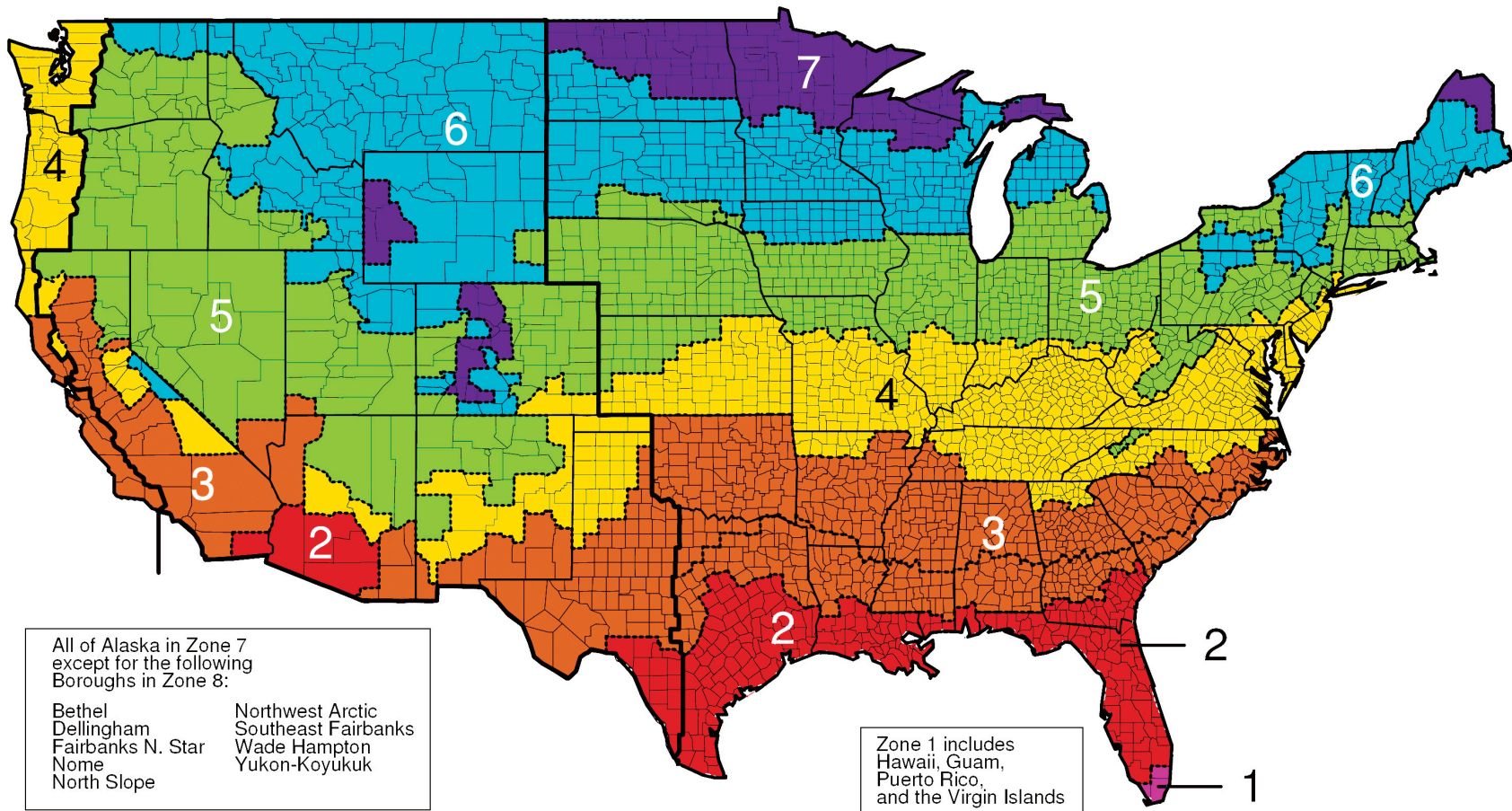
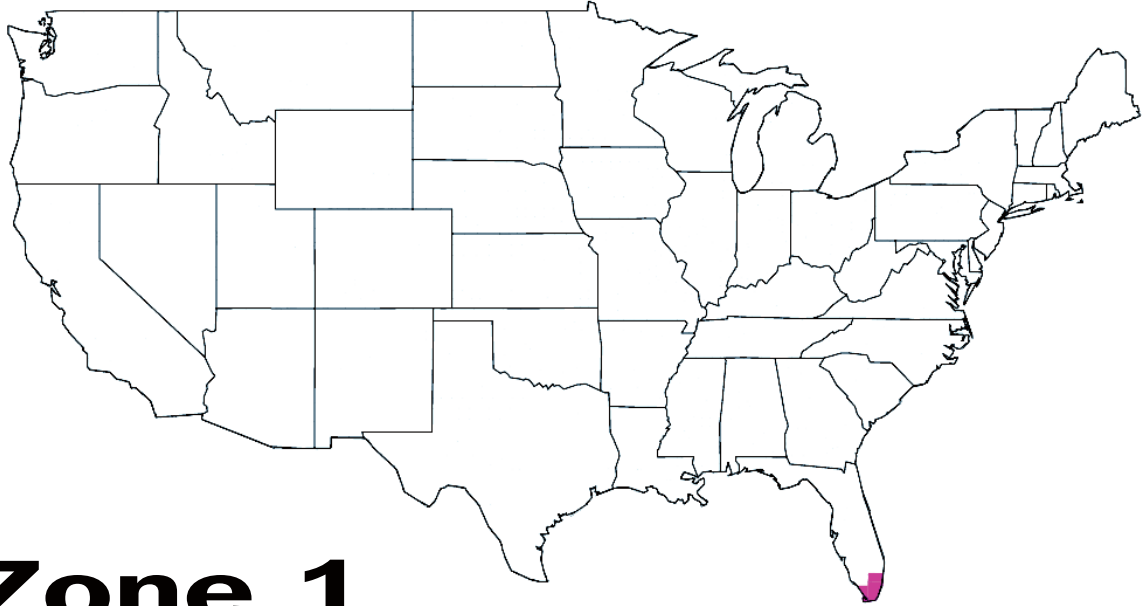

Figure 3-1. DOE climate zone map. A list of counties and their respective climate zones can be found on the following pages and at www.energycodes.gov.



Zone 1

Florida

Broward
Miami-Dade
Monroe

Guam

Hawaii

Puerto Rico

U.S. Virgin Islands

Climate Zone 1 Recommendation Table for Warehouses and Self-Storage Buildings

	Item	Component	Conditioned	Semi-heated	How-To Tips in Chapter 5	✓
Envelope	Roof	Insulation entirely above deck	R-15.0 c.i.	R-3.8 c.i.	EN1–32	
		Metal building	R-19.0	R-6.0	EN1, 4	
		Single rafter	R-30.0	R-21.0	EN1, 5	
		Solar reflectance index (SRI)	78	78	EN2	
	Walls—Exterior	Mass (HC > 7 Btu/ft ²)	No recommendation	No recommendation	EN1, 6, 15–16	
		Metal building	R-16.0	R-13.0	EN1, 7, 15–16	
		Steel framed	R-13.0	No recommendation	EN1, 8, 15–16	
		Wood framed and other	R-13.0	No recommendation	EN1, 9, 15–16	
	Walls—Interior	Partition walls (between semi-heated and conditioned spaces)	R-13.0	R-13.0	EN1	
	Slabs	Unheated	No recommendation	No recommendation	EN1, 14	
	Doors—Opaque	Swinging	U-0.700	U-0.700	EN1, 11	
		Vehicular/dock thermal transmittance	U-0.500	U-0.500	EN1, 12	
		Vehicular/dock infiltration—door closed	0.28 cfm/ft ² of door area	0.28 cfm/ft ² of door area	EN1	
		Vehicular/dock infiltration—door open with truck in place	Weatherseals for dock levelers and trailer hinges	No recommendation	EN1, 13	
	Vertical Glazing (Including Doors)	Thermal transmittance	U-0.56	U-1.20	EN1, 17, 20, 22	
		Solar heat gain coefficient (SHGC)	N, S, E, W – 0.25	No recommendation	EN1, 17, 20, 22, 24, 27	
Exterior sun control (S, E, W only)		PF > 0.5	No recommendation	EN1, 20–21, 23, 26		
Skylights	Area (percent of gross roof)	5%–7% prismatic diffusing skylights required in warehouse areas (except in self-storage areas)		EN1, 18–20		
	Thermal transmittance	U-1.36	U-1.36	EN1, 19		
	Solar heat gain coefficient (SHGC)	0.19	No recommendation	EN1, 19		
	Visible light transmittance (VLT)	0.45		EN1, 19		
Lighting	Interior Lighting	Lighting power density (LPD)	Warehouse (bulky and self storage) = 0.6 W/ft ² Warehouse (fine storage) = 0.85 W/ft ² Office area = 0.9 W/ft ²		EL12–18	
		Linear fluorescent lamps	T-5HO or T-8 high-performance with high-performance electronic ballast		EL3–7	
	Controls for daylight harvesting	Automatic dimming or switching of all luminaires in daylighted areas		DL1–10, EL9, 10		
	Occupancy controls	Auto-on/off for all luminaires in the warehouse and self-storage areas, manual-on/auto-off for all office areas		EL8		
	Ceiling surface reflectances	80%		EL2		
Exterior Lighting	Canopied areas	0.5 W/ft ²		EL19–21		
HVAC	HVAC	Cooling system (conditioned storage, all sizes)	Heat pump packaged systems for low sensible load spaces, variable-speed supply fan; inverter compressor		HV4	
		Air conditioner (0–65 KBtuh)	13.0 SEER		HV1–4, 8, 16, 18–19, 22	
		Air conditioner (>65–135 KBtuh)	11.3 EER/11.5 IPLV		HV1–4, 6, 16, 18–19, 22	
		Air conditioner (>135–240 KBtuh)	11.0 EER/11.5 IPLV		HV1–4, 6, 16, 18–19, 22	
		Air conditioner (>240 KBtuh)	10.6 EER/11.2 IPLV		HV1–4, 6, 16, 18–19, 22	
		Gas furnace (0–225 KBtuh—SP)	80% AFUE or E _t		HV1–2, 6, 16, 22	
		Gas furnace (0–225 KBtuh—Split)	80% AFUE or E _t		HV1–2, 6, 16, 22	
		Gas furnace (>225 KBtuh)	80% E _c		HV1–2, 6, 16, 22	
		Heat pump (0–65 KBtuh)	13.0 SEER/7.7 HSPF		HV1–4, 6, 16, 18–19, 22	
		Heat pump (>65–135 KBtuh)	10.6 EER/11.0 IPLV/3.2 COP		HV1–4, 6, 16, 18–19, 22	
	Heat pump (>135 KBtuh)	10.1 EER/11.5 IPLV/3.1 COP		HV1–4, 6, 16, 18–19, 22		
	De-stratification	No recommendation		HV7		
	Economizer	Air conditioners and heat pumps—SP	No recommendation		HV24	
Ventilation	Outdoor air damper	Motorized control		HV9–10		
	Air leakage through relief dampers	3 cfm/ft ² at 1 in. wg				
Ducts	Friction rate	0.08 in. w.c./100 ft		HV11, 20		
	Sealing	Seal class B		HV13		
	Location	Interior only		HV11		
	Insulation level	R-6		HV12		
SWH	Service Water Heating	Gas water heater efficiency	Storage—90% E _t , Instantaneous—0.81 EF or 81% E _t		WH1–2, 4	
		Electric storage EF (≤12 kW, ≥20 gal)	EF > 0.99 – 0.0012 × Volume		WH1–2, 4	
		Point of use heater selection	Avoid pumped return for distributed light loads		WH5	
		Water heater sizing	Avoid oversizing and excessive supply temperatures		WH3	
	Pipe insulation (d < 1½ in./ d ≥ 1½ in.)	1 in./ 1½ in.		WH6		

Note: If the table contains “No recommendation” for a component, the user must meet the more stringent of either ASHRAE/IESNA Standard 90.1 or the local code requirements in order to reach the 30% savings target.

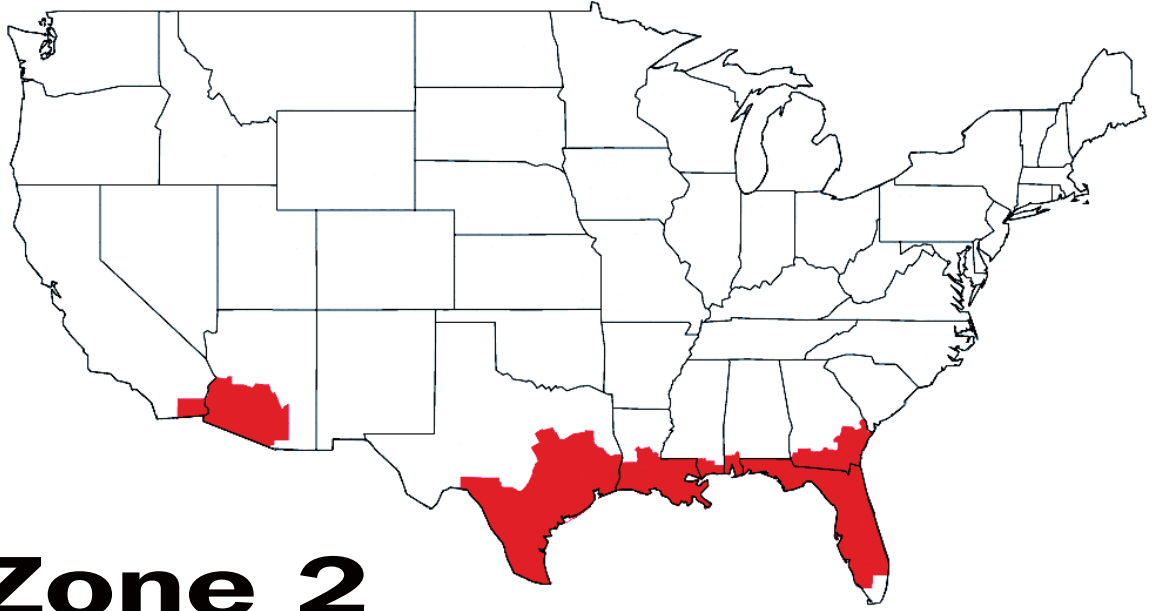

Zone 2

Alabama

Baldwin
Mobile

Arizona

La Paz
Maricopa
Pima
Pinal
Yuma

California

Imperial

Florida

Alachua
Baker
Bay
Bradford
Brevard
Calhoun
Charlotte
Citrus
Clay
Collier
Columbia
DeSoto
Dixie
Duval
Escambia
Flagler
Franklin
Gadsden
Gilchrist
Glades
Gulf
Hamilton
Hardee
Hendry
Hernando
Highlands
Hillsborough
Holmes
Indian River
Jackson
Jefferson
Lafayette
Lake
Lee
Leon

Levy
Liberty
Madison
Manatee
Marion
Martin
Nassau
Okaloosa
Okeechobee
Orange
Osceola
Palm Beach
Pasco
Pinellas
Polk
Putnam
Santa Rosa
Sarasota
Seminole
St. Johns
St. Lucie
Sumter
Suwannee
Taylor
Union
Volusia
Wakulla
Walton
Washington

Georgia

Appling
Atkinson
Bacon
Baker
Berrien
Brantley
Brooks
Bryan
Camden
Charlton
Chatham
Clinch
Colquitt
Cook
Decatur
Echols
Effingham
Evans
Glynn
Grady
Jeff Davis
Lanier

Liberty
Long
Lowndes
McIntosh
Miller
Mitchell
Pierce
Seminole
Tattnall
Thomas
Toombs
Ware
Wayne

Louisiana

Acadia
Allen
Ascension
Assumption
Avoyelles
Beauregard
Cameron
East Baton
Rouge
East Feliciana
Evangeline
Iberia
Iberville
Jefferson
Jefferson Davis
Lafayette
Lafourche
Livingston
Orleans
Plaquemines
Pointe Coupee
Rapides
St. Bernard
St. Charles
St. Helena
St. James
St. John the Baptist
St. Landry
St. Martin
St. Mary
St. Tammany
Tangipahoa
Terrebonne
Vermilion
Washington
West Baton
Rouge

West Feliciana

Mississippi

Hancock
Harrison
Jackson
Pearl River
Stone

Texas

Anderson
Angelina
Aransas
Atascosa
Austin
Bandera
Bastrop
Bee
Bell
Bexar
Bosque
Brazoria
Brazos
Brooks
Burleson
Caldwell
Calhoun
Cameron
Chambers
Cherokee
Colorado
Comal
Coryell
DeWitt
Dimmit
Duval
Edwards
Falls
Fayette
Fort Bend
Freestone
Frio
Galveston
Goliad
Gonzales
Grimes
Guadalupe
Hardin
Harris
Hays
Hidalgo
Hill

Houston
Jackson
Jasper
Jefferson
Jim Hogg
Jim Wells
Karnes
Kinney
Kinney
Kleberg
La Salle
Lavaca
Lee
Leon
Liberty
Limestone
Live Oak
Madison
Matagorda
Maverick
McLennan
McMullen
Medina
Miliam
Montgomery
Newton
Nueces
Orange
Polk
Real
Refugio
Robertson
San Jacinto
San Patricio
Starr
Travis
Trinity
Tyler
Uvalde
Val Verde
Victoria
Walker
Waller
Washington
Webb
Wharton
Willacy
Williamson
Wilson
Zapata
Zavala

Climate Zone 2 Recommendation Table for Warehouses and Self-Storage Buildings

	Item	Component	Conditioned	Semi-heated	How-To Tips in Chapter 5	✓
Envelope	Roof	Insulation entirely above deck	R-20.0 c.i.	R-3.8 c.i.	EN1-3	
		Metal building	R-13.0 + R-13.0	R-10.0	EN1, 4	
		Single rafter	R-38.0	R-21.0	EN1, 5	
		Solar reflectance index (SRI)	78	78	EN2	
	Walls—Exterior	Mass (HC > 7 Btu/ft ²)	R-5.7 c.i.	No recommendation	EN1, 6, 15-16	
		Metal building	R-16.0	R-13.0	EN1, 7, 15-16	
		Steel framed	R-13.0	R-13.0	EN1, 8, 15-16	
		Wood framed and other	R-13.0	R-13.0	EN1, 9, 15-16	
	Walls—Interior	Partition walls (between semi-heated and conditioned spaces)	R-13.0	R-13.0	EN1	
	Slabs	Unheated	No recommendation	No recommendation	EN1, 14	
	Doors—Opaque	Swinging	U-0.700	U-0.700	EN1, 11	
		Vehicular/dock thermal transmittance	U-0.500	U-0.500	EN1, 12	
		Vehicular/dock infiltration—door closed	0.28 cfm/ft ² of door area	0.28 cfm/ft ² of door area	EN1	
		Vehicular/dock infiltration—door open with truck in place	Weatherseals for dock levelers and trailer hinges	No recommendation	EN1, 13	
		Vertical Glazing (Including Doors)	Thermal transmittance	U-0.45	U-1.20	EN1, 17, 20, 22
	Skylights	Solar heat gain coefficient (SHGC)	N, S, E, W – 0.25	No recommendation	EN1, 17, 20, 22, 24, 27	
Exterior sun control (S, E, W only)		PF > 0.5	No recommendation	EN1, 20-21, 23, 26		
Area (percent of gross roof)		5%–7% prismatic diffusing skylights required in warehouse areas (except in self-storage areas)		EN1, 18-20		
Thermal transmittance		U-1.36	U-1.36	EN1, 19		
Lighting	Solar heat gain coefficient (SHGC)	0.19	No recommendation	EN1, 19		
	Visible light transmittance (VLT)	0.59		EN1, 19		
	Interior Lighting	Lighting power density (LPD)	Warehouse (bulky and self storage) = 0.6 W/ft ² Warehouse (fine storage) = 0.85 W/ft ² Office area = 0.9 W/ft ²		EL12-18	
		Linear fluorescent lamps	T-5HO or T-8 high-performance with high-performance electronic ballast		EL3-7	
Controls for daylight harvesting		Automatic dimming or switching of all luminaires in daylighted areas		DL1-10, EL9-10		
Occupancy controls		Auto-on/off for all luminaires in the warehouse and self-storage areas, manual-on/auto-off for all office areas		EL8		
Exterior Lighting	Ceiling surface reflectances	80%		EL2		
HVAC	HVAC	Canopied areas	0.5 W/ft ²		EL16-21	
		Cooling system (conditioned storage, all sizes)	Heat pump packaged systems for low sensible load spaces, variable-speed supply fan; inverter compressor		HV4	
		Air conditioner (0-65 KBtuh)	13.0 SEER		HV1-4, 8, 16, 18-19, 22	
		Air conditioner (>65-135 KBtuh)	11.3 EER/11.5 IPLV		HV1-4, 6, 16, 18-19, 22	
		Air conditioner (>135-240 KBtuh)	11.0 EER/11.5 IPLV		HV1-4, 6, 16, 18-19, 22	
		Air conditioner (>240 KBtuh)	10.6 EER/11.2 IPLV		HV1-4, 6, 16, 18-19, 22	
		Gas furnace (0-225 KBtuh—SP)	80% AFUE or E _t		HV1-2, 6, 16, 22	
		Gas furnace (0-225 KBtuh—Split)	80% AFUE or E _t		HV1-2, 6, 16, 22	
		Gas furnace (>225 KBtuh)	80% E _c		HV1-2, 6, 16, 22	
		Heat pump (0-65 KBtuh)	13.0 SEER/7.7 HSPF		HV1-4, 6, 16, 18-19, 22	
	Heat pump (>65-135 KBtuh)	10.6 EER/11.0 IPLV/3.2 COP		HV1-4, 6, 16, 18-19, 22		
	Heat pump (>135 KBtuh)	10.1 EER/11.5 IPLV/3.1 COP		HV1-4, 6, 16, 18-19, 22		
	De-stratification	No recommendation		HV7		
	Economizer	Air conditioners and heat pumps—SP	No recommendation		HV24	
Ventilation	Outdoor air damper	Motorized control		HV9-10		
	Air leakage through relief dampers	3 cfm/ft ² at 1 in. wg				
	Ducts	Friction rate	0.08 in. w.c./100 ft		HV11, 20	
SWH	Heating	Sealing	Seal class B		HV13	
		Location	Interior only		HV11	
		Insulation level	R-6		HV12	
		Gas water heater efficiency	Storage—90% E _t , Instantaneous—0.81 EF or 81% E _t		WH1-2, 4	
		Electric storage EF (≤12 kW, ≥20 gal)	EF > 0.99 – 0.0012 × Volume		WH1-2, 4	
Point of use heater selection	Avoid pumped return for distributed light loads		WH5			
Water heater sizing	Avoid oversizing and excessive supply temperatures		WH3			
Pipe insulation (d < 1½ in./ d ≥ 1½ in.)	1 in./ 1½ in.		WH6			

Note: If the table contains “No recommendation” for a component, the user must meet the more stringent of either ASHRAE/IESNA Standard 90.1 or the local code requirements in order to reach the 30% savings target.

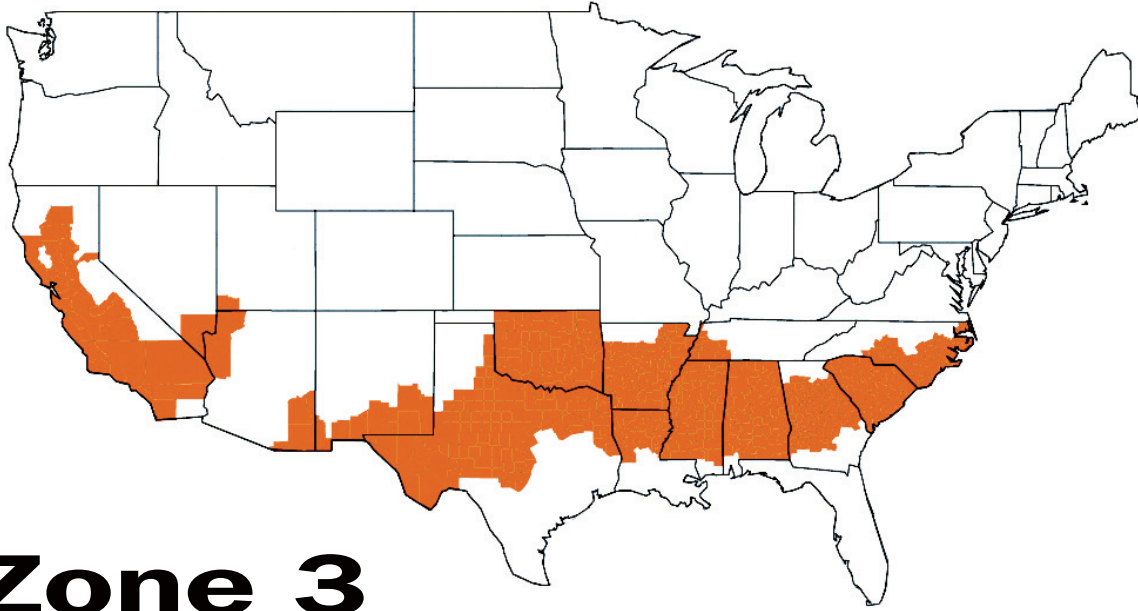

Zone 3

Alabama

All counties except: Baldwin Mobile

Arizona

Cochise Graham Greenlee Mohave Santa Cruz

Arkansas

All counties except: Baxter Benton Boone Carroll Fulton Izard Madison Marion Newton Searcy Stone Washington

California

All counties except: Alpine Amador Calaveras Del Norte El Dorado Humboldt Imperial Inyo Lake Lassen Mariposa Modoc Mono Nevada Plumas Sierra Siskiyou Trinity Tuolumne

Georgia

All counties except: Appling Atkinson Bacon Baker Banks Berrien Brantley Brooks Bryan Catoosa Camden Charlton Chatham Chattooga Clinch Colquitt Cook Dade Dawson Decatur Echols Effingham Evans Fannin Floyd Franklin Gilmer Glynn Gordon Grady Habersham Hall Jeff Davis Lanier Liberty Long Lowndes Lumpkin McIntosh Miller Mitchell Murray Pickens Pierce Rabun Seminole Stephens Tattall Thomas Toombs Towns

Union Walker Ware Wayne White Whitfield

Louisiana

Bienville Bossier Caddo Caldwell Catahoula Claiborne Concordia De Soto East Carroll Franklin Grant Jackson La Salle Lincoln Madison Morehouse Natchitoches Ouachita Red River Richland Sabine Tensas Union Vernon Webster West Carroll Winn

Mississippi

All counties except: Hancock Harrison Jackson Pearl River Stone

New Mexico

Chaves Dona Ana Eddy Hidalgo Lea Luna Otero

Nevada

Clark

Texas

Andrews Archer Baylor Blanco Borden Bowie Brewster Brown Burnet Callahan Camp Cass Childress Clay Coke Coleman Collingsworth Collin Comanche Concho Cottle Cooke Crane Crockett Crosby Culberson Dallas Dawson Delta Denton Dickens Eastland Ector El Paso Ellis Erath Fannin Fisher Foard Franklin Gaines Garza Gillespie Glasscock Grayson Gregg Hall Hamilton Hardeman Harrison Haskell Hemphill Henderson Hood Hopkins Howard Hudspeth Hunt Irion Jack Jeff Davis Johnson Jones Kaufman Kendall Kent Kerr Kimble King Knox Lamar Lampasas Llano Loving Lubbock Lynn Marion Martin Mason McCulloch Menard Midland Mills Mitchell Montague Morris Motley Nacogdoches Navarro Nolan Palo Pinto Panola Parker Pecos Presidio Rains Reagan Reeves Red River Rockwall Runnels Rusk Sabine San Augustine San Saba

Schleicher Scurry Shackelford Shelby Smith Somervell Stephens Stonewall Sutton Tarrant Taylor Terrell Terry Throckmorton Titus Tom Green Upshur Upton Van Zandt Ward Wheeler Wichita Wilbarger Winkler Wise Wood Young

Utah

Washington

North Carolina

Anson Beaufort Bladen Brunswick Cabarrus Camden Carteret Chowan Columbus Craven Cumberland Dare Davidson Duplin Edgecombe Gaston Greene Hoke Hyde Johnston

Jones Lenoir Martin Mecklenburg Montgomery Moore New Hanover Onslow Pamlico Pasquotank Pender Perquimans Pitt Randolph Richmond Robeson Rowan Sampson Scotland Stanly Tyrrell Union Washington Wayne Wilson

Oklahoma

All counties except: Beaver Cimarron Texas

South Carolina

All counties

Tennessee

Chester Crockett Dyer Fayette Hardeman Hardin Haywood Henderson Lake Lauderdale Madison McNairy Shelby Tipton

Climate Zone 3 Recommendation Table for Warehouses and Self-Storage Buildings

	Item	Component	Conditioned	Semi-heated	How-To Tips in Chapter 5	✓		
Envelope	Roof	Insulation entirely above deck	R-20.0 c.i.	R-5.0 c.i.	EN1-3			
		Metal building	R-13.0 + R-13.0	R-10.0	EN1, 4			
		Single rafter	R-38.0	R-21.0	EN1, 5			
		Solar reflectance index (SRI)	78	78	EN2			
	Walls—Exterior	Mass (HC > 7 Btu/ft ²)	R-7.6 c.i.	No recommendation	EN1, 6, 15-16			
		Metal building	R-19.0	R-13.0	EN1, 7, 15-16			
		Steel framed	R-13.0 + R-3.8 c.i.	R-13.0	EN1, 8, 15-16			
		Wood framed and other	R-13.0	R-13.0	EN1, 9, 15-16			
	Walls—Interior	Partition walls (between semi-heated and conditioned spaces)	R-13.0	R-13.0	EN1			
	Slabs	Unheated	No recommendation	No recommendation	EN1, 14			
	Doors—Opaque	Swinging	U-0.700	U-0.700	EN1, 11			
		Vehicular/dock thermal transmittance	U-0.500	U-0.500	EN1, 12			
		Vehicular/dock infiltration—door closed	0.28 cfm/ft ² of door area	0.28 cfm/ft ² of door area	EN1			
		Vehicular/dock infiltration—door open with truck in place	Weatherseals for dock levelers and trailer hinges	No recommendation	EN1, 13			
		Vertical Glazing (Including Doors)	Thermal transmittance	U-0.45	U-1.20	EN1, 17, 20, 22		
	Skylights	Solar heat gain coefficient (SHGC)	N, S, E, W – 0.25	No recommendation	EN1, 17, 20, 22, 24, 27			
		Exterior sun control (S, E, W only)	PF > 0.5	No recommendation	EN1, 20-21, 23, 26			
		Area (percent of gross roof)	5%–7% prismatic diffusing skylights required in warehouse areas (except in self-storage areas)		EN1, 18-20			
		Thermal transmittance	U-0.69	U-1.36	EN1, 19			
		Solar heat gain coefficient (SHGC)	0.19	No recommendation	EN1, 19			
Lighting	Interior Lighting	Visible light transmittance (VLT)	0.59		EN1, 19			
		Lighting power density (LPD)	Warehouse (bulky and self storage) = 0.6 W/ft ² Warehouse (fine storage) = 0.85 W/ft ² Office area = 0.9 W/ft ²		EL12-18			
		Linear fluorescent lamps	T-5HO or T-8 high-performance with high-performance electronic ballast		EL3-7			
		Controls for daylight harvesting	Automatic dimming or switching of all luminaires in daylighted areas		DL1-10, EL9-10			
	Exterior Lighting	Occupancy controls	Auto-on/off for all luminaires in the warehouse and self-storage areas, manual-on/auto-off for all office areas		EL8			
		Ceiling surface reflectances	80%		EL2			
		Canopied areas	0.5 W/ft ²		EL19-21			
		HVAC	HVAC	Cooling system (conditioned storage, all sizes)	Heat pump packaged systems for low sensible load spaces, variable-speed supply fan; inverter compressor		HV4	
				Air conditioner (0-65 KBtuh)	13.0 SEER		HV1-4, 8, 16, 18-19, 22	
				Air conditioner (>65-135 KBtuh)	11.0 EER/11.4 IPLV		HV1-4, 6, 16, 18-19, 22	
Air conditioner (>135-240 KBtuh)	10.8 EER/11.2 IPLV				HV1-4, 6, 16, 18-19, 22			
Air conditioner (>240 KBtuh)	10.0 EER/10.4 IPLV				HV1-4, 6, 16, 18-19, 22			
Gas furnace (0-225 KBtuh—SP)	80% AFUE or E _t				HV1-2, 6, 16, 22			
Gas furnace (0-225 KBtuh—Split)	80% AFUE or E _t				HV1-2, 6, 16, 22			
Gas furnace (>225 KBtuh)	80% E _c				HV1-2, 6, 16, 22			
Heat pump (0-65 KBtuh)	13.0 SEER/7.7 HSPF				HV1-4, 6, 16, 18-19, 22			
Heat pump (>65-135 KBtuh)	10.6 EER/11.0 IPLV/3.2 COP				HV1-4, 6, 16, 18-19, 22			
Heat pump (>135 KBtuh)	10.1 EER/11.0 IPLV/3.1 COP		HV1-4, 6, 16, 18-19, 22					
Economizer	Ventilation	Destratification	No recommendation		HV7			
		Air conditioners and heat pumps—SP	Cooling capacity > 54 KBtuh		HV24			
		Outdoor air damper	Motorized control		HV9-10			
		Air leakage through relief dampers	3 cfm/ft ² at 1 in. wg					
		Ducts	Friction rate	0.08 in. w.c./100 ft		HV11, 20		
SWH	Heating	Sealing	Seal class B		HV13			
		Location	Interior only		HV11			
		Insulation level	R-6		HV12			
		Gas water heater efficiency	Storage—90% E _t , Instantaneous—0.81 EF or 81% E _t		WH1-2, 4			
		Electric storage EF (≤12 kW, ≥20 gal)	EF > 0.99 – 0.0012 × Volume		WH1-2, 4			
		Point of use heater selection	Avoid pumped return for distributed light loads		WH5			
Water heater sizing	Avoid oversizing and excessive supply temperatures		WH3					
Pipe insulation (d < 1½ in./ d ≥ 1½ in.)	1 in./ 1½ in.		WH6					

Note: If the table contains “No recommendation” for a component, the user must meet the more stringent of either ASHRAE/IESNA Standard 90.1 or the local code requirements in order to reach the 30% savings target.

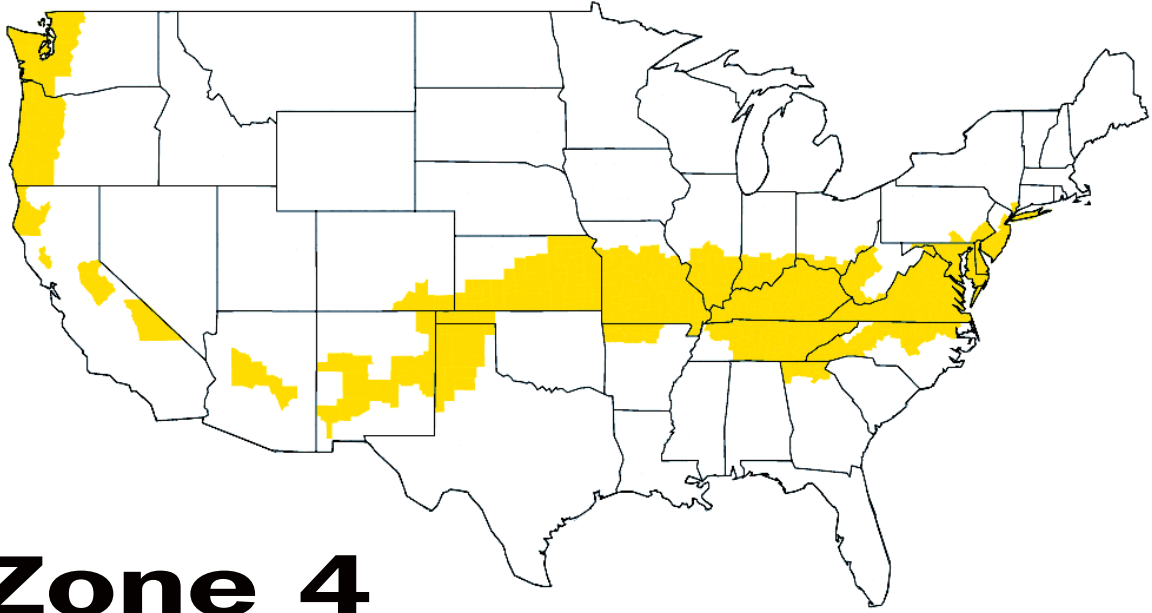

Zone 4

Arizona

Gila
Yavapai

Arkansas

Baxter
Benton
Boone
Carroll
Fulton
Izard
Madison
Marion
Newton
Searcy
Stone
Washington

California

Amador
Calaveras
Del Norte
El Dorado
Humboldt
Inyo
Lake
Mariposa
Trinity
Tuolumne

Colorado

Baca
Las Animas
Otero

Delaware

All counties

District of Columbia

Georgia

Banks
Catoosa
Chattooga
Dade
Dawson
Fannin
Floyd
Franklin
Gilmer
Gordon
Habersham
Hall
Lumpkin
Murray
Pickens
Rabun
Stephens
Towns
Union
Walker
White
Whitfield

Illinois

Alexander
Bond
Brown
Christian
Clay
Clinton
Crawford
Edwards
Effingham
Fayette
Franklin
Gallatin
Hamilton
Hardin
Jackson
Jasper
Jefferson
Johnson
Lawrence
Macoupin
Madison
Marion
Massac
Monroe
Montgomery
Perry
Pope
Pulaski
Randolph
Richland
Saline
Shelby
St. Clair
Union
Wabash
Washington
Wayne
White
Williamson

Indiana

Clark
Crawford
Davies
Dearborn
Dubois
Floyd
Gibson
Greene
Harrison
Jackson
Jefferson
Jennings
Knox
Lawrence
Martin
Monroe
Orange
Perry
Pike
Posey
Ripley

Scott
Spencer
Sullivan
Switzerland
Vanderburgh
Warrick
Washington

Kansas

All counties
except:
Cheyenne
Cloud
Decatur
Ellis
Gove
Graham
Greeley
Hamilton
Jewell
Lane
Logan
Mitchell
Ness
Norton
Osborne
Phillips
Rawlins
Republic
Rooks
Scott
Sheridan
Sherman
Smith
Thomas
Trego
Wallace
Wichita

Kentucky

All counties

Maryland

All counties
except:
Garrett

Missouri

All counties
except:
Adair
Andrew
Atchison
Buchanan
Caldwell
Chariton
Clark
Clinton
Davies
DeKalb
Perry
Grundy
Harrison
Holt

Knox
Lewis
Linn
Livingston
Macon
Marion
Mercer
Nodaway
Pike
Putnam
Ralls
Schuyler
Scotland
Shelby
Sullivan
Worth

New Jersey

All counties
except:
Bergen
Hunterdon
Mercer
Morris
Passaic
Somerset
Sussex
Warren

New Mexico

Bernalillo
Cibola
Curry
DeBaca
Grant
Guadalupe
Lincoln
Quay
Roosevelt
Sierra
Socorro
Union
Valencia

New York

Bronx
Kings
Nassau
New York
Queens
Richmond
Suffolk
Westchester

North Carolina

Alamance
Alexander
Bertie
Buncombe
Burke
Caldwell
Caswell
Catawba

Chatham
Cherokee
Clay
Cleveland
Davie
Durham
Forsyth
Franklin
Gates
Graham
Granville
Guilford
Halifax
Harnett
Haywood
Henderson
Hertford
Iredell
Jackson
Lee
Lincoln
Macon
Madison
McDowell
Nash
Northampton
Orange
Person
Polk
Rockingham
Rutherford
Stokes
Surry
Swain
Transylvania
Vance
Wake
Warren
Wilkes
Yadkin

Ohio

Adams
Brown
Clermont
Gallia
Hamilton
Lawrence
Pike
Scioto
Washington

Oklahoma

Beaver
Cimarron
Texas

Oregon

Benton
Clackamas
Clatsop
Columbia
Coos
Curry

Douglas
Jackson
Josephine
Lane
Lincoln
Linn
Marion
Multnomah
Polk
Tillamook
Washington
Yamhill

Pennsylvania

Bucks
Chester
Delaware
Montgomery
Philadelphia
York

Tennessee

All counties
except:
Chester
Crockett
Dyer
Fayette
Hardeman
Hardin
Haywood
Henderson
Lake
Lauderdale
Madison
McNairy
Shelby
Tipton

Texas

Armstrong
Bailey
Briscoe
Carson
Castro
Cochran
Dallam
Deaf Smith
Donley
Floyd
Gray
Hale
Hansford
Hartley
Hockley
Hutchinson
Lamb
Lipscomb
Moore
Ochiltree
Oldham
Parmer
Potter
Randall

Roberts
Sherman
Swisher
Yoakum

Virginia

All counties

Washington

Clallam
Clark
Cowlitz
Grays Harbor
Island
Jefferson
King
Kitsap
Lewis
Mason
Pacific
Pierce
San Juan
Skagit
Snohomish
Thurston
Wahkiakum
Whatcom

West Virginia

Berkeley
Boone
Braxton
Cabell
Calhoun
Clay
Gilmer
Jackson
Jefferson
Kanawha
Lincoln
Logan
Mason
McDowell
Mercer
Mingo
Monroe
Morgan
Pleasants
Putnam
Ritchie
Roane
Tyler
Wayne
Wirt
Wood
Wyoming

Climate Zone 4 Recommendation Table for Warehouses and Self-Storage Buildings

	Item	Component	Conditioned	Semi-heated	How-To Tips in Chapter 5	✓
Envelope	Roof	Insulation entirely above deck	R-20.0 c.i.	R-5.0 c.i.	EN1-3	
		Metal building	R-13.0 + R-19.0	R-10.0	EN1, 4	
		Single rafter	R-38.0	R-30.0	EN1, 5	
		Solar reflectance index (SRI)	No recommendation	No recommendation	EN2	
	Walls—Exterior	Mass (HC > 7 Btu/ft ²)	R-9.5 c.i.	No recommendation	EN1, 6, 15-16	
		Metal building	R-19.0	R-13.0	EN1, 7, 15-16	
		Steel framed	R-13.0 + R-7.5 c.i.	R-13.0	EN1, 8, 15-16	
		Wood framed and other	R-13.0	R-13.0	EN1, 9, 15-16	
	Walls—Interior	Partition walls (between semi-heated and conditioned spaces)	R-13.0	R-13.0	EN1	
	Slabs	Unheated	No recommendation	No recommendation	EN1, 14	
	Doors—Opaque	Swinging	U-0.700	U-0.700	EN1, 11	
		Vehicular/dock thermal transmittance	U-0.500	U-0.500	EN1, 12	
		Vehicular/dock infiltration—door closed	0.28 cfm/ft ² of door area	0.28 cfm/ft ² of door area	EN1	
		Vehicular/dock infiltration—door open with truck in place	Weatherseals for dock levelers and trailer hinges	Weatherseals for dock levelers and trailer hinges	EN1, 13	
		Thermal transmittance	U-0.42	U-1.20	EN1, 17, 20, 22	
	Vertical Glazing (Including Doors)	Solar heat gain coefficient (SHGC)	N, S, E, W – 0.40	No recommendation	EN1, 17, 20, 22, 24, 27	
		Exterior sun control (S, E, W only)	PF > 0.5	No recommendation	EN1, 20-21, 23, 26	
		Area (percent of gross roof)	5%–7% prismatic diffusing skylights required in warehouse areas (except in self-storage areas)		EN1, 18-20	
	Skylights	Thermal transmittance	U-0.69	U-1.36	EN1, 19	
		Solar heat gain coefficient (SHGC)	0.39	No recommendation	EN1, 19	
Visible light transmittance (VLT)		0.59		EN1, 19		
Lighting power density (LPD)		Warehouse (bulky and self storage) = 0.6 W/ft ² Warehouse (fine storage) = 0.85 W/ft ² Office area = 0.9 W/ft ²		EL12-18		
Lighting	Linear fluorescent lamps	T-5HO or T-8 high-performance with high-performance electronic ballast		EL3-7		
	Controls for daylight harvesting	Automatic dimming or switching of all luminaires in daylighted areas		DL1-10, EL9-10		
	Occupancy controls	Auto-on/off for all luminaires in the warehouse and self-storage areas, manual-on/auto-off for all office areas		EL8		
	Ceiling surface reflectances	80%		EL2		
	Exterior Lighting	Canopied areas	0.5 W/ft ²		EL19-21	
HVAC	HVAC	Cooling system (conditioned storage, all sizes)	Heat pump packaged systems for low sensible load spaces, variable-speed supply fan; inverter compressor.		HV4	
		Air conditioner (0-65 KBtuh)	13.0 SEER		HV1-4, 8, 16, 18-19, 22	
		Air conditioner (>65-135 KBtuh)	11.0 EER/11.4 IPLV		HV1-4, 6, 16, 18-19, 22	
		Air conditioner (>135-240 KBtuh)	10.8 EER/11.2 IPLV		HV1-4, 6, 16, 18-19, 22	
		Air conditioner (>240 KBtuh)	10.0 EER/10.4 IPLV		HV1-4, 6, 16, 18-19, 22	
		Gas furnace (0-225 KBtuh—SP)	80% AFUE or E _t		HV1-2, 6, 16, 22	
		Gas furnace (0-225 KBtuh—Split)	80% AFUE or E _t		HV1-2, 6, 16, 22	
		Gas furnace (>225 KBtuh)	80% E _c		HV1-2, 6, 16, 22	
		Heat pump (0-65 KBtuh)	13.0 SEER/7.7 HSPF		HV1-4, 6, 16, 18-19, 22	
		Heat pump (>65-135 KBtuh)	10.6 EER/11.0 IPLV/3.2 COP		HV1-4, 6, 16, 18-19, 22	
	Heat pump (>135 KBtuh)	10.1 EER/11.0 IPLV/3.1 COP		HV1-4, 6, 16, 18-19, 22		
	Destratification	No recommendation		HV7		
	Economizer	Air conditioners and heat pumps—SP	Cooling capacity > 54 KBtuh		HV24	
	Ventilation	Outdoor air damper	Motorized control		HV9-10	
		Air leakage through relief dampers	3 cfm/ft ² at 1 in. wg			
Ducts		Friction rate	0.08 in. w.c./100 ft		HV11, 20	
SWH	Heating	Sealing	Seal class B		HV13	
		Location	Interior only		HV11	
		Insulation level	R-6		HV12	
		Gas water heater efficiency	Storage—90% E _t , Instantaneous—0.81 EF or 81% E _t		WH1-2, 4	
		Electric storage EF (≤12 kW, ≥20 gal)	EF > 0.99 – 0.0012 × Volume		WH1-2, 4	
		Point of use heater selection	Avoid pumped return for distributed light loads		WH5	
Water heater sizing	Avoid oversizing and excessive supply temperatures		WH3			
Pipe insulation (d < 1½ in./ d ≥ 1½ in.)	1 in./ 1½ in.		WH6			

Note: If the table contains “No recommendation” for a component, the user must meet the more stringent of either ASHRAE/IESNA Standard 90.1 or the local code requirements in order to reach the 30% savings target.

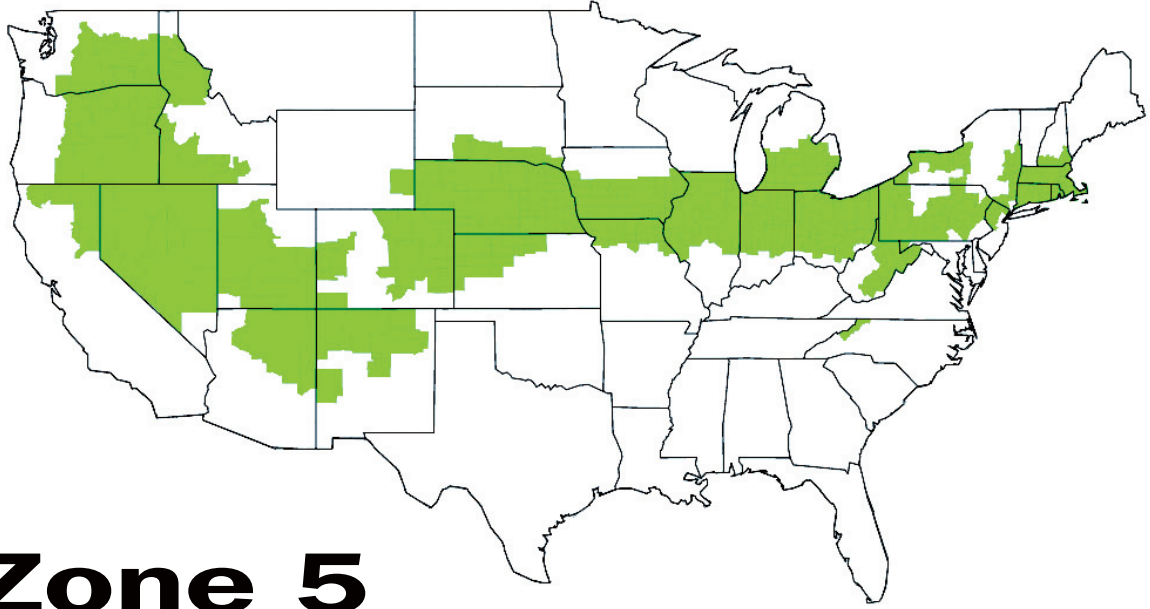

Zone 5

Arizona

Apache
Coconino
Navajo

California

Lassen
Modoc
Nevada
Plumas
Sierra
Siskiyou

Colorado

Adams
Arapahoe
Bent
Boulder
Cheyenne
Crowley
Delta
Denver
Douglas
Elbert
El Paso
Fremont
Garfield
Gilpin
Huerfano
Jefferson
Kiowa
Kit Carson
La Plata
Larimer
Lincoln
Logan
Mesa
Montezuma
Montrose
Morgan
Phillips
Prowers
Pueblo
Sedgwick
Teller
Washington
Weld
Yuma

Connecticut

All counties

Idaho

Ada
Benewah
Canyon
Cassia
Clearwater
Elmore
Gem
Gooding
Idaho
Jerome
Kootenai
Latah

Lewis
Lincoln
Minidoka
Nez Perce
Owyhee
Payette
Power
Shoshone
Twin Falls
Washington

Illinois

All counties
except:
Alexander
Bond
Christian
Clay
Clinton
Crawford
Edwards
Effingham
Fayette
Franklin
Gallatin
Hamilton
Hardin
Jackson
Jasper
Jefferson
Johnson
Lawrence
Macoupin
Madison
Marion
Massac
Monroe
Montgomery
Perry
Pope
Pulaski
Randolph
Richland
Saline
Shelby
St. Clair
Union
Wabash
Washington
Wayne
White
Williamson
Brown

Indiana

All counties
except:
Clark
Crawford
Davies
Dearborn
Dubois
Floyd
Gibson
Greene
Harrison

Jackson
Jefferson
Jennings
Knox
Lawrence
Martin
Monroe
Ohio
Orange
Perry
Pike
Posey
Ripley
Scott
Spencer
Sullivan
Switzerland
Vanderburgh
Warrick
Washington

Iowa

All counties
except:
Allamakee
Black Hawk
Bremer
Buchanan
Buena Vista
Butler
Calhoun
Cerro Gordo
Cherokee
Chickasaw
Clay
Clayton
Delaware
Dickinson
Emmet
Fayette
Floyd
Franklin
Grundy
Hamilton
Hancock
Hardin
Howard
Humboldt
Ida
Kossuth
Lyon
Mitchell
O'Brien
Osceola
Palo Alto
Plymouth
Pocahontas
Sac
Sioux
Webster
Winnebago
Winneshiek
Worth
Wright

Kansas

Cheyenne
Cloud
Decatur
Ellis
Gove
Graham
Greeley
Hamilton
Jewell
Lane
Logan
Mitchell
Ness
Norton
Osborne
Phillips
Rawlins
Republic
Rooks
Scott
Sheridan
Sherman
Smith
Thomas
Trego
Wallace
Wichita

Maryland

Garrett

Massachusetts

All counties

Michigan

Allegan
Barry
Bay
Berrien
Branch
Calhoun
Cass
Clinton
Eaton
Genesee
Gratiot
Hillsdale
Ingham
Ionia
Jackson
Kalamazoo
Kent
Lapeer
Lenawee
Livingston
Macomb
Midland
Monroe
Montcalm
Muskegon
Oakland
Ottawa
Saginaw
Shiawassee

St. Clair
St. Joseph
Tuscola
Van Buren
Washtenaw
Wayne

Missouri

Adair
Andrew
Atchison
Buchanan
Caldwell
Chariton
Clark
Clinton
Davies
DeKalb
Gentry
Grundy
Harrison
Holt
Knox
Lewis
Linn
Livingston
Macon
Marion
Mercer
Nodaway
Pike
Putnam
Ralls
Schuyler
Scotland
Shelby
Sullivan
Worth

Nebraska

All counties

Nevada

All counties
except:
Clark

New Hampshire

Cheshire
Hillsborough
Rockingham
Strafford

New Jersey

Bergen
Hunterdon
Mercer
Morris
Passaic
Somerset
Sussex
Warren

New Mexico

Catron
Colfax

Harding
Los Alamos
McKinley
Mora
Rio Arriba
Sandoval
San Juan
San Miguel
Santa Fe
Taos
Torrance

New York

Albany
Cayuga
Chautauqua
Chernung
Columbia
Cortland
Dutchess
Erie
Genesee
Greene
Livingston
Monroe
Niagara
Onondaga
Ontario
Orange
Orleans
Oswego
Putnam
Rensselaer
Rockland
Saratoga
Schenectady
Seneca
Tioga
Washington
Wayne
Yates

North Carolina

Alleghany
Ashe
Avery
Mitchell
Watauga
Yancey

Ohio

All counties
except:
Adams
Brown
Clermont
Gallia
Hamilton
Lawrence
Pike
Scioto
Washington

Oregon

Baker
Crook

Deschutes
Gilliam
Grant
Harney
Hood River
Jefferson
Klamath
Lake
Malheur
Morrow
Sherman
Umatilla
Union
Wallowa
Wasco
Wheeler

Pennsylvania

All counties
except:
Bucks
Cameron
Chester
Clearfield
Delaware
Elk
McKean
Montgomery
Philadelphia
Potter
Susquehanna
Tioga
Wayne
York

Rhode Island

All counties

South Dakota

Bennett
Bon Homme
Charles Mix
Clay
Douglas
Gregory
Hutchinson
Jackson
Mellette
Todd
Tripp
Union
Yankton

Utah

All counties
except:
Box Elder
Cache
Carbon
Daggett
Duchesne
Morgan
Rich
Summit
Uintah

Washington

Adams
Asotin
Benton
Chelan
Columbia
Douglas
Franklin
Garfield
Grant
Kittitas
Klickitat
Lincoln
Skamania
Spokane
Walla Walla
Whitman
Yakima

Wyoming

Goshen
Platte

West Virginia

Barbour
Brooke
Doddridge
Fayette
Grant
Greenbrier
Hampshire
Hancock
Hardy
Harrison
Lewis
Marshall
Mineral
Monongalia
Nicholas
Ohio
Pendleton
Pocahontas
Preston
 Raleigh
Randolph
Summers
Taylor
 Tucker
Upsher
Webster
Wetzel

Climate Zone 5 Recommendation Table for Warehouses and Self-Storage Buildings

	Item	Component	Conditioned	Semi-heated	How-To Tips in Chapter 5	✓
Envelope	Roof	Insulation entirely above deck	R-20.0 c.i.	R-7.6 c.i.	EN1-3	
		Metal building	R-13.0 + R-19.0	R-13.0	EN1, 4	
		Single rafter	R-38.0 + R-5.0 c.i.	R-30.0	EN1, 5	
		Solar reflectance index (SRI)	No recommendation	No recommendation	EN2	
	Walls—Exterior	Mass (HC > 7 Btu/ft ²)	R-11.4 c.i.	R-5.7 c.i.	EN1, 6, 15-16	
		Metal building	R-19.0 + R-5.6 c.i.	R-13.0	EN1, 7, 15-16	
		Steel framed	R-13.0 + R-7.5 c.i.	R-13.0	EN1, 8, 15-16	
		Wood framed and other	R-13.0 + R-3.8 c.i.	R-13.0	EN1, 9, 15-16	
	Walls—Interior	Partition walls (between semi-heated and conditioned spaces)	R-13.0	R-13.0	EN1	
	Slabs	Unheated	No recommendation	No recommendation	EN1, 14	
	Doors—Opaque	Swinging	U-0.700	U-0.700	EN1, 11	
		Vehicular/dock thermal transmittance	U-0.500	U-0.500	EN1, 12	
		Vehicular/dock infiltration—door closed	0.28 cfm/ft ² of door area	0.28 cfm/ft ² of door area	EN1	
	Vertical Glazing (Including Doors)	Vehicular/dock infiltration—door open with truck in place	Weatherseals for dock levelers and trailer hinges	Weatherseals for dock levelers and trailer hinges	EN1, 13	
		Thermal transmittance	U-0.42	U-1.20	EN1, 17, 20, 22	
		Solar heat gain coefficient (SHGC)	N, S, E, W – 0.40	No recommendation	EN1, 17, 20, 22, 27	
		Exterior sun control (S, E, W only)	PF > 0.5	No recommendation	EN1, 20-21, 23, 25	
	Skylights	Area (percent of gross roof)	5%–7% prismatic diffusing skylights required in warehouse areas (except in self-storage areas)		EN1, 18-20	
		Thermal transmittance	U-0.69	U-1.36	EN1, 19	
		Solar heat gain coefficient (SHGC)	0.39	No recommendation	EN1, 19	
Visible light transmittance (VLT)		0.59		EN1, 19		
Lighting	Interior Lighting	Lighting power density (LPD)	Warehouse (bulky and self storage) = 0.6 W/ft ² Warehouse (fine storage) = 0.85 W/ft ² Office area = 0.9 W/ft ²		EL12-18	
		Linear fluorescent lamps	T-5HO or T-8 high-performance with high-performance electronic ballast		EL3-7	
	Controls for daylight harvesting	Automatic dimming or switching of all luminaires in daylighted areas		DL1-10, EL9-10		
	Occupancy controls	Auto-on/off for all luminaires in the warehouse and self-storage areas, manual-on/auto-off for all office areas		EL8		
	Ceiling surface reflectances	80%		EL2		
Exterior Lighting	Canopied areas	0.5 W/ft ²		EL19-21		
HVAC	HVAC	Cooling system (conditioned storage, all sizes)	Heat pump packaged systems for low sensible load spaces, variable-speed supply fan; inverter compressor.		HV4	
		Air conditioner (0-65 KBtuh)	13.0 SEER		HV1-4, 8, 16, 18-19, 22	
		Air conditioner (>65-135 KBtuh)	11.0 EER/11.4 IPLV		HV1-4, 6, 16, 18-19, 22	
		Air conditioner (>135-240 KBtuh)	10.8 EER/11.2 IPLV		HV1-4, 6, 16, 18-19, 22	
		Air conditioner (>240 KBtuh)	10.0 EER/10.4 IPLV		HV1-4, 6, 16, 18-19, 22	
		Gas furnace (0-225 KBtuh—SP)	80% AFUE or 81% E _t		HV1-2, 6, 16, 22	
		Gas furnace (0-225 KBtuh—Split)	90% AFUE or E _t		HV1-2, 6, 16, 22	
		Gas furnace (>225 KBtuh)	82% E _c or 81% E _t		HV1-2, 6, 16, 22	
		Heat pump (0-65 KBtuh)	13.0 SEER/7.7 HSPF		HV1-4, 6, 16, 18-19, 22	
		Heat pump (>65-135 KBtuh)	10.6 EER/11.0 IPLV/3.2 COP		HV1-4, 6, 16, 18-19, 22	
	Heat pump (>135 KBtuh)	10.1 EER/11.0 IPLV/3.1 COP		HV1-4, 6, 16, 18-19, 22		
	Destratification	Destratifying fans for high bay spaces		HV7		
	Economizer	Air conditioners and heat pumps—SP	Cooling capacity > 54 KBtuh		HV24	
	Ventilation	Outdoor air damper	Motorized control		HV9-10	
		Air leakage through relief dampers	3 cfm/ft ² at 1 in. wg			
Ducts	Friction rate	0.08 in. w.c./100 ft		HV11, 20		
	Sealing	Seal class B		HV13		
	Location	Interior only		HV11		
	Insulation level	R-6		HV12		
SWH	Service Water Heating	Gas water heater efficiency	Storage—90% E _t , Instantaneous—0.81 EF or 81% E _t		WH1-2, 4	
		Electric storage EF (≤12 kW, ≥20 gal)	EF > 0.99 – 0.0012 × Volume		WH1-2, 4	
		Point of use heater selection	Avoid pumped return for distributed light loads		WH5	
		Water heater sizing	Avoid oversizing and excessive supply temperatures		WH3	
		Pipe insulation (d < 1½ in./ d ≥ 1½ in.)	1 in./ 1½ in.		WH6	

Note: If the table contains "No recommendation" for a component, the user must meet the more stringent of either ASHRAE/IESNA Standard 90.1 or the local code requirements in order to reach the 30% savings target.

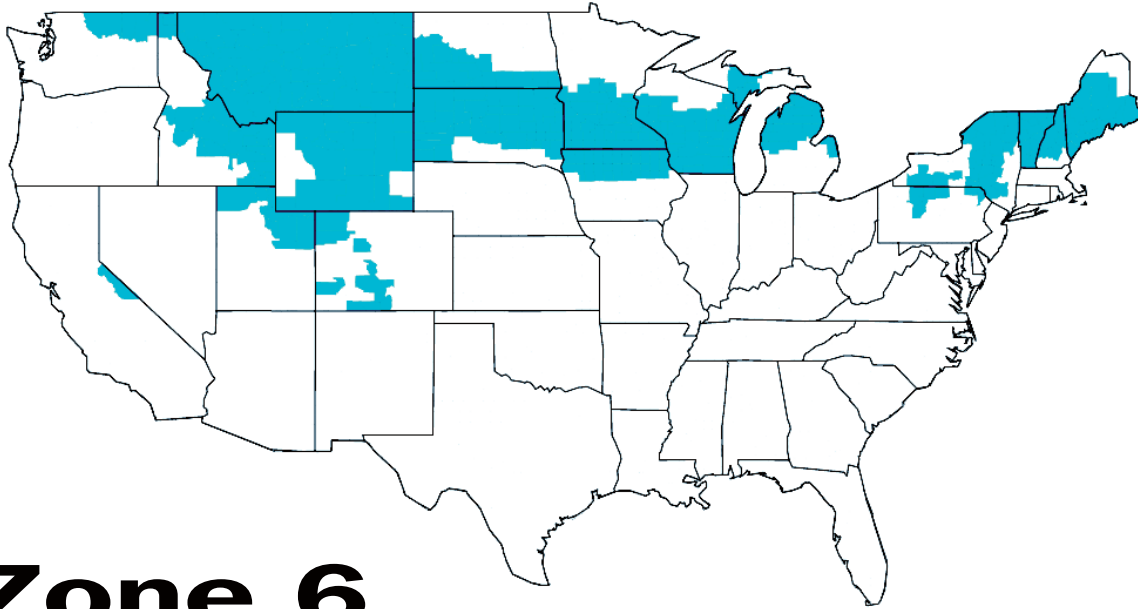

Zone 6

California

Alpine
Mono

Colorado

Alamosa
Archuleta
Chaffee
Conejos
Costilla
Custer
Dolores
Eagle
Moffat
Ouray
Rio Blanco
Saguache
San Miguel

Idaho

Adams
Bannock
Bear Lake
Bingham
Blaine
Boise
Bonner
Bonneville
Boundary
Butte
Camas
Caribou
Clark
Custer
Franklin
Fremont
Jefferson
Lemhi
Madison
Oneida
Teton
Valley

Iowa

Allamakee
Black Hawk

Bremer
Buchanan
Buena Vista
Butler
Calhoun
Cerro Gordo
Cherokee
Chickasaw
Clay
Clayton
Delaware
Dickinson
Emmet
Gladwin
Hamilton
Hancock
Hardin
Howard
Humboldt
Ida
Kossuth
Lyon
Mitchell
O'Brien
Osceola
Palo Alto
Plymouth
Pocahontas
Sac
Sioux
Webster
Winnebago
Winneshek
Worth
Wright

Maine

All counties
except:
Aroostook

Michigan

Alcona
Alger

Alpena
Antrim
Arenac
Benzie
Charlevoix
Cheboygan
Clare
Crawford
Delta
Dickinson
Emmet
Gladwin
Grand Traverse
Huron
Iosco
Isabella
Kalkaska
Lake
Leelanau
Manistee
Marquette
Mason
Mecosta
Menominee
Missaukee
Montmorency
Newaygo
Oceana
Ogemaw
Osceola
Oscoda
Otsego
Presque Isle
Roscommon
Sanilac
Wexford

Minnesota

Anoka
Benton
Big Stone
Blue Earth
Brown
Carver
Chippewa
Chisago
Cottonwood
Dakota

Dodge
Douglas
Faribault
Fillmore
Freeborn
Goodhue
Hennepin
Houston
Isanti
Jackson
Kandiyohi
Lac qui Parle
Le Sueur
Lincoln
Lyon
Martin
McLeod
Meeker
Morrison
Mower
Murray
Nicollet
Nobles
Olmsted
Pipestone
Pope
Ramsey
Redwood
Renville
Rice
Rock
Scott
Sherburne
Sibley
Stearns
Steele
Stevens
Swift
Todd
Traverse
Wabasha
Waseca
Washington
Watonwan
Winona
Wright
Yellow Medicine

Montana

All counties

New Hampshire

Belknap
Carroll
Coos
Grafton
Merrimack
Sullivan

New York

Allegany
Broome
Cattaraugus
Chenango
Clinton
Delaware
Essex
Franklin
Fulton
Hamilton
Herkimer
Jefferson
Lewis
Madison
Montgomery
Oneida
Otsego
Schoharie
Schuyler
Steuben
St. Lawrence
Sullivan
Tompkins
Ulster
Warren
Wyoming

North Dakota

Adams
Billings
Bowman
Burleigh
Dickey
Dunn

Emmons
Golden Valley
Grant
Hettinger
LaMoure
Logan
McIntosh
McKenzie
Mercer
Morton
Oliver
Ransom
Richland
Sargent
Sioux
Slope
Stark

Pennsylvania

Cameron
Clearfield
Elk
McKean
Potter
Susquehanna
Tioga
Wayne

South Dakota

All counties
except:
Bennett
Bon Homme
Charles Mix
Clay
Douglas
Gregory
Hutchinson
Jackson
Mellette
Todd
Tripp
Union
Yankton

Utah

Box Elder
Cache

Carbon
Daggett
Duchesne
Morgan
Rich
Summit
Uintah
Wasatch

Vermont

All counties

Washington

Ferry
Okanogan
Pend Oreille
Stevens

Wisconsin

All counties
except:
Ashland
Bayfield
Burnett
Douglas
Florence
Forest
Iron
Langlade
Lincoln
Oneida
Price
Sawyer
Taylor
Vilas
Washburn

Wyoming

All counties
except:
Goshen
Platte
Lincoln
Sublette
Teton

Climate Zone 6 Recommendation Table for Warehouses and Self-Storage Buildings

	Item	Component	Conditioned	Semi-heated	How-To Tips in Chapter 5	✓
Envelope	Roof	Insulation entirely above deck	R-20.0 c.i.	R-10.0 c.i.	EN1-3	
		Metal building	R-13.0 + R-19.0	R-16.0	EN1, 4	
		Single rafter	R-38.0 + R-5.0 c.i.	R-38.0	EN1, 5	
		Solar reflectance index (SRI)	No recommendation	No recommendation	EN2	
	Walls—Exterior	Mass (HC > 7 Btu/ft ²)	R-13.3 c.i.	R-5.7 c.i.	EN1, 6, 15-16	
		Metal building	R-19.0 + R-5.6 c.i.	R-13.0	EN1, 7, 15-16	
		Steel framed	R-13.0 + R-7.5 c.i.	R-13.0	EN1, 8, 15-16	
		Wood framed and other	R-13.0 + R-7.5 c.i.	R-13.0	EN1, 9, 15-16	
	Walls—Interior	Partition walls (between semi-heated and conditioned spaces)	R-13.0	R-13.0	EN1	
	Slabs	Unheated	R-10.0 for 24 in.	No recommendation	EN1, 10, 14	
	Doors—Opaque	Swinging	U-0.700	U-0.700	EN1, 11	
		Vehicular/dock thermal transmittance	U-0.500	U-0.500	EN1, 12	
		Vehicular/dock infiltration—door closed	0.28 cfm/ft ² of door area	0.28 cfm/ft ² of door area	EN1	
		Vehicular/dock infiltration—door open with truck in place	Weatherseals for dock levelers and trailer hinges	Weatherseals for dock levelers and trailer hinges	EN1, 13	
		Vertical Glazing (Including Doors)	Thermal transmittance	U-0.42	U-0.60	EN1, 17, 20, 22
	Skylights	Solar heat gain coefficient (SHGC)	N, S, E, W – 0.40	No recommendation	EN1, 17, 20, 22, 27	
		Exterior sun control (S, E, W only)	PF > 0.5	No recommendation	EN1, 20-21, 23, 25	
		Area (percent of gross roof)	5%–7% prismatic diffusing skylights required in warehouse areas (except in self-storage areas)		EN1, 18-20	
	Lighting	Interior Lighting	Thermal transmittance	U-0.69	U-1.36	EN1, 19
Solar heat gain coefficient (SHGC)			0.49	No recommendation	EN1, 19	
Visible light transmittance (VLT)			0.59		EN1, 19	
Lighting power density (LPD)			Warehouse (bulky and self storage) = 0.6 W/ft ² Warehouse (fine storage) = 0.85 W/ft ² Office area = 0.9 W/ft ²		EL12-18	
HVAC	Interior Lighting	Linear fluorescent lamps	T-5HO or T-8 high-performance with high-performance electronic ballast		EL3-7	
		Controls for daylight harvesting	Automatic dimming or switching of all luminaires in daylighted areas		DL1-10, EL9-10	
		Occupancy controls	Auto-on/off for all luminaires in the warehouse and self-storage areas, manual-on/auto-off for all office areas		EL8	
		Ceiling surface reflectances	80%		EL2	
HVAC	Exterior Lighting	Canopied areas	0.5 W/ft ²		EL19-21	
		HVAC	Cooling system (conditioned storage, all sizes)	No recommendation		
	Air conditioner (0-65 KBtuh)		13.0 SEER		HV1-4, 8, 16, 18-19, 22	
	Air conditioner (>65-135 KBtuh)		11.0 EER/11.4 IPLV		HV1-4, 6, 16, 18-19, 22	
	Air conditioner (>135-240 KBtuh)		10.8 EER/11.2 IPLV		HV1-4, 6, 16, 18-19, 22	
	Air conditioner (>240 KBtuh)		10.0 EER/10.4 IPLV		HV1-4, 6, 16, 18-19, 22	
	Gas furnace (0-225 KBtuh—SP)		80% AFUE or 81% E _t		HV1-2, 6, 16, 22	
	Gas furnace (0-225 KBtuh—Split)		90% AFUE or E _t		HV1-2, 6, 16, 22	
	Gas furnace (>225 KBtuh)		82% E _c or 81% E _t		HV1-2, 6, 16, 22	
	Heat pump (0-65 KBtuh)		13.0 SEER/7.7 HSPF		HV1-4, 6, 16, 18-19, 22	
	Heat pump (>65-135 KBtuh)		No recommendation		HV1-4, 6, 16, 18-19, 22	
	Heat pump (>135 KBtuh)		No recommendation		HV1-4, 6, 16, 18-19, 22	
	Destratification		Destratifying fans for high bay spaces		HV7	
	Economizer		Air conditioners and heat pumps—SP	Cooling capacity > 54 KBtuh		HV24
	Ventilation	Outdoor air damper	Motorized control		HV9-10	
Air leakage through relief dampers		3 cfm/ft ² at 1 in. wg				
Ducts		Friction rate	0.08 in. w.c./100 ft		HV11, 20	
	Sealing	Seal class B		HV13		
	Location	Interior only		HV11		
	Insulation level	R-6		HV12		
SWH	Service Water Heating	Gas water heater efficiency	Storage—90% E _t , Instantaneous—0.81 EF or 81% E _t		WH1-2, 4	
		Electric storage EF (≤12 kW, ≥20 gal)	EF > 0.99 – 0.0012 × Volume		WH1-2, 4	
		Point of use heater selection	Avoid pumped return for distributed light loads		WH5	
		Water heater sizing	Avoid oversizing and excessive supply temperatures		WH3	
		Pipe insulation (d < 1½ in./ d ≥ 1½ in.)	1 in./ 1½ in.		WH6	

Note: If the table contains “No recommendation” for a component, the user must meet the more stringent of either ASHRAE/IESNA Standard 90.1 or the local code requirements in order to reach the 30% savings target.

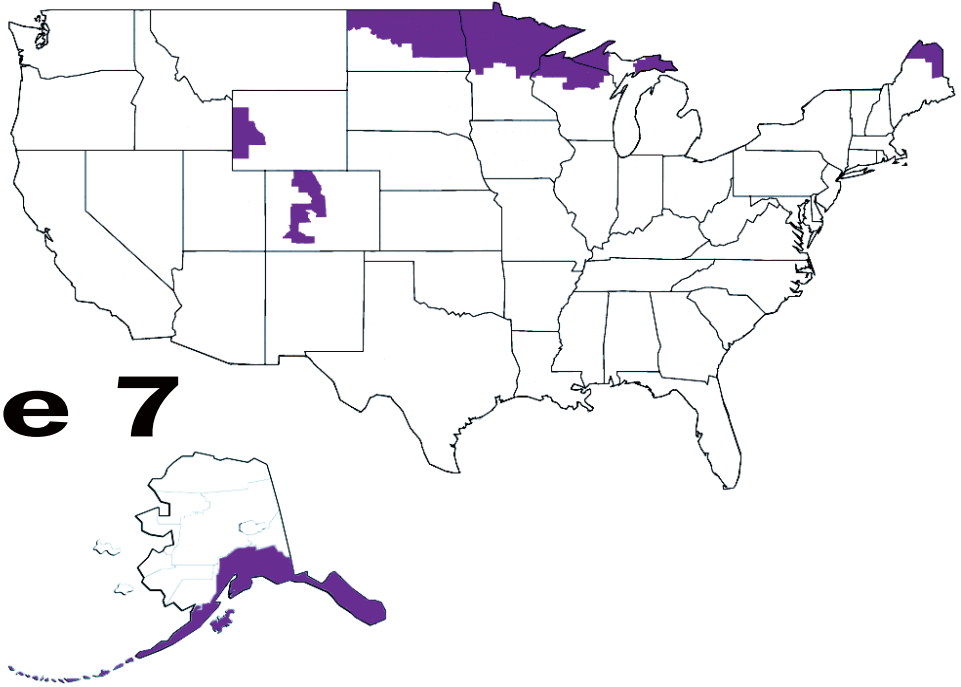

Zone 7

Alaska

- Aleutians East
- Aleutians West (CA)
- Anchorage
- Angoon (CA)
- Bristol Bay
- Denali
- Haines
- Juneau
- Kenai Peninsula
- Ketchikan (CA)
- Ketchikan Gateway
- Kodiak Island
- Lake and Peninsula
- Matanuska-Susitna
- Prince of Wales-Outer Sitka
- Skagway-Hoonah-Valdez-Cordova (CA)
- Wrangell-Petersburg (CA)
- Yakutat

Colorado

- Clear Creek
- Grand
- Gunnison
- Hinsdale
- Jackson
- Lake
- Mineral
- Park
- Pitkin
- Rio Grande
- Routt
- San Juan

Maine

- Aroostook

Michigan

- Baraga
- Chippewa
- Gogebic
- Houghton
- Iron
- Keweenaw
- Luce
- Mackinac
- Ontonagon
- Schoolcraft

Minnesota

- Aitkin
- Becker
- Beltrami
- Carlton
- Cass
- Clay
- Clearwater
- Cook
- Crow Wing
- Grant
- Hubbard
- Itasca
- Kanabec
- Kittson
- Koochiching
- Lake

- Summit

- Lake of the Woods
- Mahnomen
- Marshall
- Mille Lacs
- Norman
- Otter Tail
- Pennington
- Pine
- Polk
- Red Lake
- Roseau
- St. Louis
- Wadena
- Wilkin

North Dakota

- Barnes
- Benson
- Bottineau
- Burke
- Cass
- Cavalier
- Divide
- Eddy
- Foster
- Grand Forks
- Griggs
- Kidder
- McHenry
- McLean
- Mountrail
- Nelson
- Pembina
- Pierce
- Ramsey
- Renville

- Rolette
- Sheridan
- Steele
- Stutsman
- Towner
- Trail
- Walsh
- Ward
- Wells
- Williams

Wisconsin

- Ashland
- Bayfield
- Burnett
- Douglas
- Florence
- Forest
- Iron
- Langlade
- Lincoln
- Oneida
- Price
- Sawyer
- Taylor
- Vilas
- Washburn

Wyoming

- Lincoln
- Sublette
- Teton

Climate Zone 7 Recommendation Table for Warehouses and Self-Storage Buildings

	Item	Component	Conditioned	Semi-heated	How-To Tips in Chapter 5	✓
Envelope	Roof	Insulation entirely above deck	R-20.0 c.i.	R-10.0 c.i.	EN1–3	
		Metal building	R-13.0 + R-19.0	R-16.0	EN1, 4	
		Single rafter	R-38.0 + R-10.0 c.i.	R-38.0	EN1, 5	
		Solar reflectance index (SRI)	No recommendation	No recommendation	EN2	
	Walls—Exterior	Mass (HC > 7 Btu/ft ²)	R-15.2 c.i.	R-7.6 c.i.	EN1, 6, 15–16	
		Metal building	R-19.0 + R-11.2 c.i.	R-13.0	EN1, 7, 15–16	
		Steel framed	R-13.0 + R-7.5 c.i.	R-13.0	EN1, 8, 15–16	
		Wood framed and other	R-13.0 + R-7.5 c.i.	R-13.0	EN1, 9, 15–16	
	Walls—Interior	Partition walls (between semi-heated and conditioned spaces)	R-13.0	R-13.0	EN1	
	Slabs	Unheated	R-15.0 for 24 in.	No recommendation	EN1, 10, 14	
	Doors—Opaque	Swinging	U-0.500	U-0.700	EN1, 11	
		Vehicular/dock thermal transmittance	U-0.500	U-0.500	EN1, 12	
		Vehicular/dock infiltration—door closed	0.28 cfm/ft ² of door area	0.28 cfm/ft ² of door area	EN1	
		Vehicular/dock infiltration—door open with truck in place	Weatherseals for dock levelers and trailer hinges	Weatherseals for dock levelers and trailer hinges	EN1, 13	
		Thermal transmittance	U-0.33	U-0.60	EN1, 17, 20, 22	
	Vertical Glazing (Including Doors)	Solar heat gain coefficient (SHGC)	N, S, E, W – 0.45	No recommendation	EN1, 17, 20, 22, 27	
		Exterior sun control (S, E, W only)	PF > 0.5	No recommendation	EN1, 20–21, 23, 25	
		Area (percent of gross roof)	5%–7% prismatic diffusing skylights required in warehouse areas (except in self-storage areas)		EN1, 18–20	
	Skylights	Thermal transmittance	U-0.69	U-1.36	EN1, 19	
		Solar heat gain coefficient (SHGC)	0.64	No recommendation	EN1, 19	
Visible light transmittance (VLT)		0.59		EN1, 19		
Lighting power density (LPD)		Warehouse (bulky and self storage) = 0.6 W/ft ² Warehouse (fine storage) = 0.85 W/ft ² Office area = 0.9 W/ft ²		EL12–18		
Lighting	Linear fluorescent lamps	T-5HO or T-8 high-performance with high-performance electronic ballast		EL3–7		
	Controls for daylight harvesting	Automatic dimming or switching of all luminaires in daylighted areas		DL1–10, EL9–10		
	Occupancy controls	Auto-on/off for all luminaires in the warehouse and self-storage areas, manual-on/auto-off for all office areas		EL8		
	Ceiling surface reflectances	80%		EL2		
	Exterior Lighting	Canopied areas	0.5 W/ft ²	EL19–21		
HVAC	HVAC	Cooling system (conditioned storage, all sizes)	No recommendation			
		Air conditioner (0–65 KBtuh)	13.0 SEER		HV1–4, 8, 16, 18–19, 22	
		Air conditioner (>65–135 KBtuh)	No recommendation		HV1–4, 6, 16, 18–19, 22	
		Air conditioner (>135–240 KBtuh)	No recommendation		HV1–4, 6, 16, 18–19, 22	
		Air conditioner (>240 KBtuh)	No recommendation		HV1–4, 6, 16, 18–19, 22	
		Gas furnace (0–225 KBtuh—SP)	80% AFUE or 81% E _t		HV1–2, 6, 16, 22	
		Gas furnace (0–225 KBtuh—Split)	90% AFUE or E _t		HV1–2, 6, 16, 22	
		Gas furnace (>225 KBtuh)	82% E _c or 81% E _t		HV1–2, 6, 16, 22	
		Heat pump (0–65 KBtuh)	13.0 SEER/7.7 HSPF		HV1–4, 6, 16, 18–19, 22	
		Heat pump (>65–135 KBtuh)	No recommendation		HV1–4, 6, 16, 18–19, 22	
	Heat pump (>135 KBtuh)	No recommendation		HV1–4, 6, 16, 18–19, 22		
	Destratification	Destratifying fans for high bay spaces		HV7		
	Economizer	Air conditioners and heat pumps—SP	No recommendation		HV24	
	Ventilation	Outdoor air damper	Motorized control		HV9–10	
		Air leakage through relief dampers	3 cfm/ft ² at 1 in. wg			
Ducts		Friction rate	0.08 in. w.c./100 ft		HV11, 20	
SWH	Heating	Sealing	Seal class B		HV13	
		Location	Interior only		HV11	
		Insulation level	R-6		HV12	
		Gas water heater efficiency	Storage—90% E _t , Instantaneous—0.81 EF or 81% E _t		WH1–2, 4	
		Electric storage EF (≤12 kW, ≥20 gal)	EF > 0.99 – 0.0012 × Volume		WH1–2, 4	
Point of use heater selection	Avoid pumped return for distributed light loads		WH5			
Water heater sizing	Avoid oversizing and excessive supply temperatures		WH3			
Pipe insulation (d < 1½ in./ d ≥ 1½ in.)	1 in./ 1½ in.		WH6			

Note: If the table contains “No recommendation” for a component, the user must meet the more stringent of either ASHRAE/IESNA Standard 90.1 or the local code requirements in order to reach the 30% savings target.

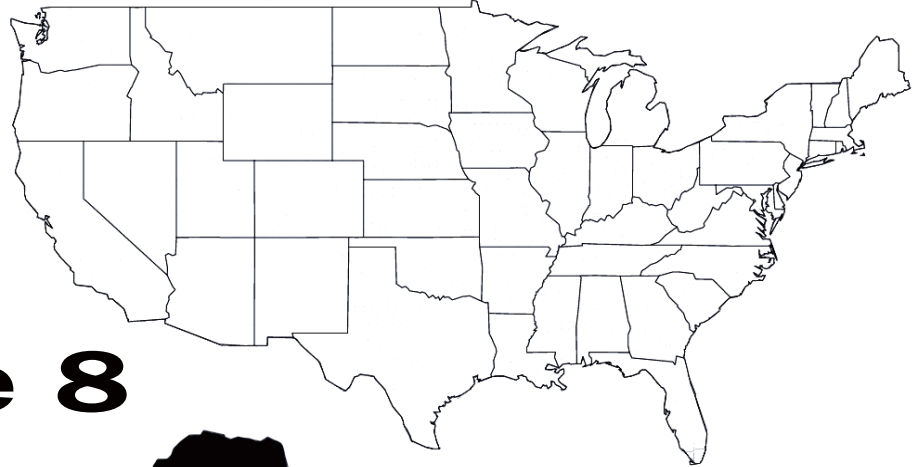

Zone 8



Alaska

- Bethel (CA)
- Dillingham (CA)
- Fairbanks North Star
- Nome (CA)
- North Slope
- Northwest Arctic
- Southeast Fairbanks (CA)
- Wade Hampton (CA)
- Yukon-Koyukuk (CA)

Climate Zone 8 Recommendation Table for Warehouses and Self-Storage Buildings

	Item	Component	Conditioned	Semi-heated	How-To Tips in Chapter 5	✓	
Envelope	Roof	Insulation entirely above deck	R-30.0 c.i.	R-15.0 c.i.	EN1-3		
		Metal building	R-11.0 + R-30.0 Is	R-19.0	EN1, 4		
		Single rafter	R-38.0 + R-10.0 c.i.	R-38.0	EN1, 5		
		Solar reflectance index (SRI)	No recommendation	No recommendation	EN2		
	Walls—Exterior	Mass (HC > 7 Btu/ft ²)	R-15.2 c.i.	R-9.5 c.i.	EN1, 6, 15-16		
		Metal building	R-19.0 + R-11.2 c.i.	R-13.0	EN1, 7, 15-16		
		Steel framed	R-13.0 + R-7.5 c.i.	R-13.0 + R-3.8 c.i.	EN1, 8, 15-16		
		Wood framed and other	R-13.0 + R-15.6 c.i.	R-13.0	EN1, 9, 15-16		
	Walls—Interior	Partition walls (between semi-heated and conditioned spaces)	R-13.0	R-13.0	EN1		
	Slabs	Unheated	R-20.0 for 24 in.	No recommendation	EN1, 10, 14		
	Doors—Opaque	Swinging	U-0.500	U-0.700	EN1, 11		
		Vehicular/dock thermal transmittance	U-0.500	U-0.500	EN1, 12		
		Vehicular/dock infiltration—door closed	0.28 cfm/ft ² of door area	0.28 cfm/ft ² of door area	EN1		
		Vehicular/dock infiltration—door open with truck in place	Weatherseals for dock levelers and trailer hinges	Weatherseals for dock levelers and trailer hinges	EN1, 13		
		Thermal transmittance	U-0.33	U-0.60	EN1, 17, 20, 22		
	Vertical Glazing (Including Doors)	Solar heat gain coefficient (SHGC)	N, S, E, W – 0.45	No recommendation	EN1, 17, 20, 22, 27		
		Exterior sun control (S, E, W only)	PF>0.5	No recommendation	EN1, 20-21, 23, 25		
	Skylights	Area (percent of gross roof)	No skylights recommended in warehouse areas due to winter heat loss and minimal daylight availability				
	Lighting	Interior Lighting	Lighting power density (LPD)	Warehouse (bulky and self storage) = 0.6 W/ft ² Warehouse (fine storage) = 0.85 W/ft ² Office area = 0.9 W/ft ²		EL12-18	
Linear fluorescent lamps			T-5HO or T-8 high-performance with high-performance electronic ballast		EL3-7		
Controls for daylight harvesting		Automatic dimming or switching of all luminaires in daylighted areas		DL1-10, EL9-10			
Occupancy controls		Auto-on/off for all luminaires in the warehouse and self-storage areas, manual-on/auto-off for all office areas		EL8			
Ceiling surface reflectances		80%		EL2			
Exterior Lighting		Canopied areas	0.5 W/ft ²		EL19-21		
HVAC	HVAC	Cooling system (conditioned storage, all sizes)	No recommendation				
		Air conditioner (0-65 KBtuh)	13.0 SEER		HV1-4, 8, 16, 18-19, 22		
		Air conditioner (>65-135 KBtuh)	No recommendation		HV1-4, 6, 16, 18-19, 22		
		Air conditioner (>135-240 KBtuh)	No recommendation		HV1-4, 6, 16, 18-19, 22		
		Air conditioner (>240 KBtuh)	No recommendation		HV1-4, 6, 16, 18-19, 22		
		Gas furnace (0-225 KBtuh—SP)	80% AFUE or 81% E _t		HV1-2, 6, 16, 22		
		Gas furnace (0-225 KBtuh—Split)	90% AFUE or E _t		HV1-2, 6, 16, 22		
		Gas furnace (>225 KBtuh)	82% E _c or 81% E _t		HV1-2, 6, 16, 22		
		Heat pump (0-65 KBtuh)	13.0 SEER/7.7 HSPF		HV1-4, 6, 16, 18-19, 22		
		Heat pump (>65-135 KBtuh)	No recommendation		HV1-4, 6, 16, 18-19, 22		
		Heat pump (>135 KBtuh)	No recommendation		HV1-4, 6, 16, 18-19, 22		
		Air conditioner (storage, all sizes)	No recommendation		HV4		
		Destratification	Destratifying fans for high bay spaces		HV7		
		Economizer	Air conditioners and heat pumps—SP	No recommendation		HV24	
		Ventilation	Outdoor air damper	Motorized control		HV9-10	
Air leakage through relief dampers	3 cfm/ft ² at 1 in. wg						
Ducts	Friction rate		0.08 in. w.c./100 ft		HV11, 20		
	Ducts	Sealing	Seal class B		HV13		
		Location	Interior only		HV11		
		Insulation level	R-8		HV12		
		Service Water Heating	Service Water Heating	Gas water heater efficiency	Storage—90% E _t , Instantaneous—0.81 EF or 81% E _t		WH1-2, 4
Electric storage EF (≤12 kW, ≥20 gal)	EF > 0.99 – 0.0012 × Volume			WH1-2, 4			
Point of use heater selection	Avoid pumped return for distributed light loads			WH5			
Water heater sizing	Avoid oversizing and excessive supply temperatures			WH3			
Pipe insulation (d < 1½ in./ d ≥ 1½ in.)	1 in./ 1½ in.			WH6			

Note: If the table contains “No recommendation” for a component, the user must meet the more stringent of either ASHRAE/IESNA Standard 90.1 or the local code requirements in order to reach the 30% savings target.

Technology Examples and Case Studies **4_H**

Chapter 4 presents technology examples and case studies of buildings that are consistent with the recommendations presented in this Guide. The technology examples represent a specific portion of the building that would contribute toward meeting the energy target—such as lighting, equipment efficiencies, or envelope measures. The case studies are buildings that meet the energy target.

CLIMATE ZONE 4—TACOMA POWER & LIGHT NEW SHOPS BUILDING (LEED CERTIFIED)

TACOMA, WASHINGTON

Tacoma Power & Light's new shops building, located in climate zone 4, is LEED® certified. The building has all the practical features required for the utility company's craft shops for transformers, welding, carpentry, painting, and other necessities. But the building also has features that add energy efficiency and environmental friendliness to the 55,000 ft² building and provide a work space that is comfortable and efficient.

Using building criteria from the USGBC's Leadership in Energy and Environmental Design (LEED) Green Building Rating System™, Tacoma Power & Light received



Photograph courtesy of Tacoma Power & Light

Figure 4-1. Tacoma Power & Light new shops building featuring an array of skylights for interior daylighting.



Photographs courtesy of Michael Lane

Figure 4-2. Interior views of the daylighting and lighting systems for the Tacoma Power & Light new shops building.

green building certification. While many typical environmental features do not apply to industrial buildings, a number of green design features were incorporated into the building.

The shops, with 20 ft ceilings, use high-efficiency fluorescent lighting. They also have skylights and a system that automatically turns off some of the lights when natural daylight reaches a certain level. Lighting fixtures are on occupancy sensors and have dimming controls as well. (See Figure 4.2.) The heating and cooling system also takes advantage of energy-saving technologies.

Hot water for work sinks and in restrooms comes from “instant hot” fixtures, not from traditional water heaters.

Estimates are that the building uses at least 40% less electricity than a similar building with standard lighting, heating, and hot-water systems.

Many of the materials used in the building meet LEED thresholds for recycled content and for being produced locally, and 97% of the construction waste was recycled instead of going to a landfill. The building also recycles paper, cardboard, glass, plastics, and metals.

Other features include ozone-friendly refrigerants for the cooling system and adhesives, sealants, and paints with low emissions.

TACOMA POWER & LIGHT NEW SHOPS BUILDING	
Energy Savings Measures	Description of Project Elements
Lighting	
<i>Electric Lighting Design</i>	Overhead lighting is high-performance T-8 lamps and ballasts in a four-lamp, 8 ft configuration. Overall lighting (including permanent task lighting) is roughly 0.91 W/ft ² .
<i>Daylighting</i>	Skylight Characteristics: 0.47 U-factor, 0.56 VLT, 0.65 SHGC (Note: does not include the effect of the skylight well.)
<i>Lighting Controls</i>	Uses stepped dimming system that steps the lighting to half off and full off at appropriate daylighting levels. Uses master time clock that turns lighting off during unoccupied periods. Uses manual switches for task lighting. Has occupancy sensors for all other interior lighting.
HVAC	
<i>Equipment</i>	Utilizes a ground-source heat pump system with a supply well and an injection well connected to a chiller loop via heat exchangers to provide both heating and cooling to four-pipe fan-coil units in each zone.
<i>Design Efficiencies</i>	19.6 EER cooling design efficiency; 4.2 COP heating design efficiency.

CLIMATE ZONE 5—STEELCARE INC. WAREHOUSE

PORT OF HAMILTON, ONTARIO, CANADA

Steelcare Inc., a subsidiary of Carego Holdings Inc. of Hamilton, Ontario, Canada, operates a state-of-the-art steel coil warehouse on a reclaimed eight-acre site at the Port of Hamilton. The temperature- and humidity-controlled facility is the first industrial building in Canada to earn LEED Gold certification from the Canada Green Building Council. The added cost to achieve LEED certification was easily recovered within two years due to the subsequent energy efficiency of the building.

The warehouse was designed using an integrated design approach that included both the building elements and the building functions. The result is a high-performance building that has achieved 56% better performance than Canada's National Energy Code, 40% less consumption of potable water, and a dramatic reduction of potential

**Figure 4-3.** Exterior view of Steelcare, Inc.

Photograph courtesy of Carego Holdings, Inc.

**(a)****(b)**

Photographs courtesy of Carego Holdings, Inc.

Figure 4-4. Steelcare Inc.'s (a) automated storage systems and (b) solar collector on south wall.

contaminants in stormwater runoff as compared to a traditional building. In addition, storage operations are fully automated (see Figure 4.4a) and run by a software logic that is programmed to use a minimum amount of energy.

Abcott Construction Ltd., based in Brantford, Ontario, was awarded the contract to build the building with a standing seam metal roof system. The roof has an interior liner to create a sandwich panel insulated to R-30. The insulation system supplies increased thermal efficiency through multiple layers of insulation. The walls are insulated by conventional type blanket to R-20.

At 2.51 W/m^2 , the warehouse's LPDs are lower than Canada's Model National Energy Code requirements of 5 W/m^2 . Because all storage activities are automated, 86% of the floor area is effectively a "lights out" facility, with occupancy sensors controlling the lighting fixtures.

An innovative feature is the use of a solar collector attached to the exterior of the building's south-facing wall (see Figure 4.4b). As ventilation air is pulled through it, it is heated by the solar radiation absorbed by the metal cladding and is distributed throughout the warehouse. The ventilation air must be heated all year to avoid condensation on the steel stored in the warehouse. An automated building management system controls the humidity and temperature of the facility using sensor data collected throughout the building.

The mechanical design of the building includes infrared natural gas tube heaters, a heat recovery ventilator, and a carbon dioxide (CO_2) monitoring system. Potable water use was dramatically reduced through the use of water-efficient landscaping, waterless urinals, and low-flow lavatories, showerheads, and kitchen faucets, as well as through the use of a rainwater cistern to run the toilet system.

STEELCARE INC. WAREHOUSE	
Energy Savings Measures	Description of Project Elements
Building Design/Layout	
<i>Building Layout</i>	Designed to minimize building volume, energy loss, and humidity gain.
<i>Material Handling Equipment and Material Process Flow</i>	Fully automated with smart programming to use minimum energy in operations; variable-speed control.
Envelope	
<i>Building Orientation</i>	NE-SW
Lighting	
<i>Electric Lighting Design</i>	T-8 fluorescent/MH400 W with Hi/Lo control.
<i>Lighting Controls</i>	Occupancy sensors used throughout warehouse.
Daylighting	
<i>Window Design</i>	Windows (only in the office) are operating, aluminum with thermal break, double-glazed, argon filled (12 mm space) with low-e coating.
HVAC	
<i>Equipment</i>	Uses solar collector, heat recovery ventilator, and radiant tube heaters. Office HVAC has gas heating/ electric cooling units.
<i>Design Efficiencies</i>	Solar collector saves 11,000 m^3 /yr of natural gas. Heat recovery ventilator effectiveness = 59%; office HVAC = 79% AFUE.
System Controls	
<i>Measurement and Verification</i>	Automated building management control system.
<i>Temperature Control</i>	Automated building management control system.
<i>CO₂ Sensors</i>	Monitoring throughout building.
Additional Savings	
<i>Exterior Lighting</i>	Minimized usage on property.

CLIMATE ZONE 7—BIGHORN HOME IMPROVEMENT CENTER

SILVERTHORNE, CO

The BigHorn Home Improvement Center in climate zone 7 is a mountain retail and warehouse building that includes an 18,400 ft² retail store and a 24,000 ft² lumber warehouse. The semi-heated warehouse area is on a north-south axis with an insulated translucent skylight along the ridge of the roof and a transpired solar collector on the south wall (see Figures 4.6a and 4.6b, respectively). Both the retail/office space and warehouse are single-story, open interior floor plans with small mezzanines and an approximately 18° sloped roof. The warehouse mezzanine is located along the north wall of the warehouse and is used for storage and as a pathway to the retail/office space.

Design features such as daylighting and natural ventilation reduce lighting and cooling loads. The extensive use of natural light, combined with energy-efficient electrical lighting design, provides good illumination along with the energy savings. This daylighting and lighting design resulted in a 93% reduction in lighting energy use in the

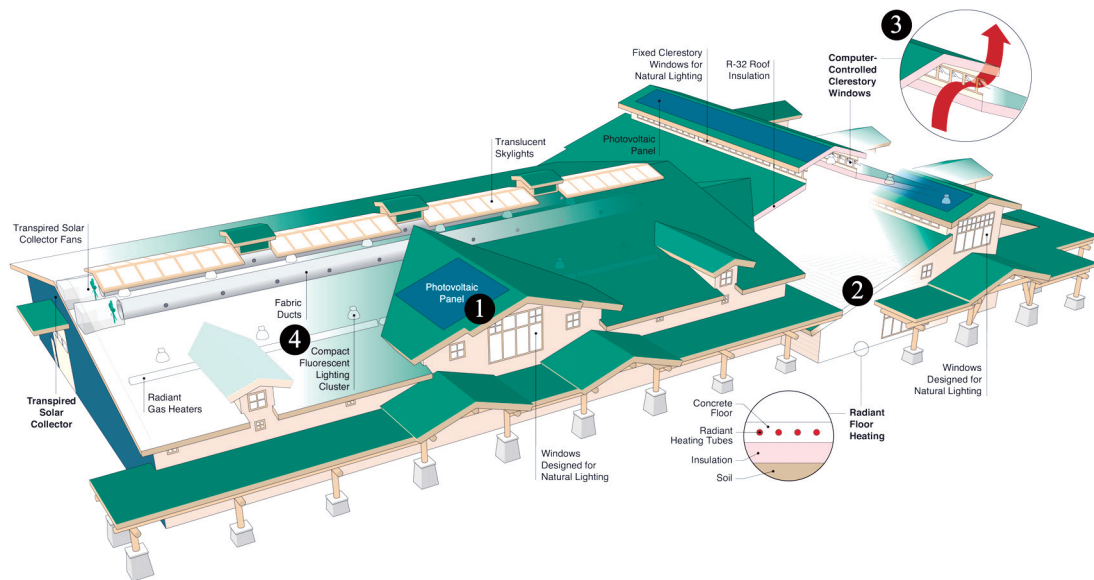

Image courtesy of DOE/NREL

Figure 4-5. Energy features: (1) photovoltaic panels, (2) radiant floor heating, (3) natural ventilation, and (4) daylighting.



(a)



(b)

Photographs provided by DOE/NREL

Figure 4-6. (a) Insulated translucent skylights and (b) transpired solar collector on south wall.

warehouse. The reduced lighting loads, management of solar gains, and a cool climate allow natural ventilation to meet the cooling loads. Design changes were also made during construction to improve energy performance, including:

- The number of lighting fixtures was reduced from the original design, which reduced the LPD by 30% and still met the minimum illumination requirements. In addition, some lighting fixtures were relocated to avoid producing bright spots and shadows.
- The lamps used in the pendant light fixtures were changed from high-intensity discharge (HID) lamps to CFLs so they could be switched on/off with the daylighting controls.

A smart envelope design and an energy management system further reduce energy consumption. Other energy features include a transpired solar collector and gas radiant heaters to heat the warehouse, an 8.9 kW roof-integrated photovoltaic system that offsets electrical energy consumption, and on-site wetland areas that were expanded and used in the development of the storm water management plan. Detailed monitoring and analysis have shown that the BigHorn Home Improvement Center uses 36% less energy than typical, minimally code-compliant buildings of similar size.

Additional information on this building is available from the National Renewable Energy Laboratory (NREL) in their technical report, “Energy Design and Performance Analysis of the BigHorn Home Improvement Center,” which is available online at www.nrel.gov/docs/fy05osti/34930.pdf.

BIGHORN HOME IMPROVEMENT CENTER WAREHOUSE	
Energy Savings Measures	Description of Project Elements
Envelope	
<i>Building Orientation</i>	North-south axis
<i>Opaque Components</i>	Slab and foundation insulation with R-10 ft ² ·°F·h/Btu and thermal breaks installed. Wall R-value at R-19 (insulated cavity between metal studs at 24in.); roof R-value at R-38.
Lighting	
<i>Electric Lighting Design</i>	CFLs with some T-8 fluorescents. Warehouse LPD at 0.6 W/ft ² .
<i>Daylighting</i>	Insulated translucent skylights along ridge of roof. Skylight characteristics: 0.1 U-factor, 0.22 SHGC.
<i>Lighting Controls</i>	Motion sensors in restrooms. Photo sensors in large areas. Stepped lighting controls (five lighting level steps).
HVAC	
<i>Equipment</i>	Gas radiant heaters.
<i>Design Efficiencies</i>	Nine radiant heating zones regulated by EMS with wall- and slab-mounted temperature sensors.
Natural Ventilation	
<i>Design Efficiencies</i>	Natural ventilation via thermostatically controlled clerestory windows and manually operated doors. Effective opening areas on clerestory at 170 ft ² and ground levels at 200 ft ² .
<i>Additional Controls</i>	Carbon monoxide (CO) sensors activate roof-mounted exhaust fans when ventilation from vehicle exhaust is needed.
Additional Savings	
<i>Solar Energy</i>	Transpired solar collector installed on south wall of warehouse to minimize the load on other heating systems in the warehouse space.

How to Implement Recommendations

5

Recommendations are contained in the individual tables in Chapter 3, “Recommendations by Climate.” The following how-to tips are intended to provide guidance on good practices for implementing the recommendations as well as cautions to avoid known problems in energy-efficient construction.

QUALITY ASSURANCE

Quality and performance are never an accident. They are always the result of high intention, sincere effort, intelligent direction, and skilled execution. A high-quality building that functions in accordance with its design intent, and thus meets the performance goals established for it, requires that quality assurance (QA) be an integral part of the design and construction process as well as the continued operation of the facility. This process is typically referred to as *commissioning*.

To reduce project risk, commissioning (Cx) requires a dedicated person (one with no other project responsibilities) who can execute a systematic process that verifies that the systems and assemblies perform as required. An independent party, whether it is a third-party Cx professional or a capable member of the organization of the installing contractor, architect, or engineer of record, is needed to ensure that the strategy sets and recommendations contained in this Guide meet the owner’s stated requirements. This person is the commissioning authority, or CxA.

The Cx process defined by *ASHRAE Guideline 0, The Commissioning Process*, and *ASHRAE Guideline 1, The HVAC Commissioning Process*, is applicable to all buildings. Owners, occupants, and the delivery team benefit equally from the QA process. Large and complex buildings require a correspondingly greater level of effort than that required for small, simpler buildings. Warehouse buildings covered by this Guide have relatively simple systems and generally do not require the level of Cx effort required for more complex buildings. The following Cx practice recommendations meet this objective.

Activity	Complete
Owner selects CxA/QA provider and commitment to QA to designers and, through the contract documents, to contractors. The owner's responsibility includes directing the team to resolve issues identified through the QA process.	
CxA/QA provider reviews the OPR and the designers' basis-of-design documentation for completeness and clarity and identifies areas requiring further clarification.	
CxA/QA provider conducts focused review of 100% construction documents that verifies the design meets the defined objectives and criteria established by OPR and documents concerns to owner and designers.	
CxA/QA provider reviews comments from design review with designers and owner and adjudicates issues.	
CxA/QA provider develops Cx specifications that define team roles and responsibilities and pass/fail criteria for performance verification.	
CxA/QA provider assists design team by providing overview of process to prospective bidders and answers questions at pre-bid meeting.	
CxA/QA provider prepares pre-functional checklists and Cx plan and conducts meeting with project team and establishes tentative schedule for Cx activities.	
CxA/QA provider reviews submittal information for systems being commissioned and develops functional test procedures contractors will use to demonstrate commissioned system performance.	
CxA/QA provider conducts two site visits during construction to verify that concerns identified during 100% construction document review were corrected and to identify issues that would affect performance.	
CxA/QA provider schedules testing through GC and directs, witnesses, and documents the functional testing that demonstrates performance.	
CxA/QA provider reviews O&M information and verifies that owner is trained in warranty and preventive maintenance requirements and has operational and maintenance information needed to meet the requirements.	

Note that the following how-to tips address the recommendations in Chapter 3, as they are generally applicable to many specific construction projects.

Good Design Practice

QA1 Select Team

Selection of the correct team members is critical to the success of a project. Owners who understand the connection between a building's performance and its impact on the environment, the psychological and physiological perceptions of occupants, and the total cost of ownership also understand the importance of team dynamics in selecting the team members responsible for delivering their project. Owners should evaluate qualifications of candidates, their past performance, the cost of their services, and their availability when making a selection. Once the team is selected, a pre-design meeting should be held to define team members' roles and responsibilities. This includes defining deliverables at each phase of the process and the Cx process.

QA2 Selection of Quality Assurance Provider

Quality assurance is a systematic process of verifying the Owner's Project Requirements, operational needs, and Basis of Design and ensuring that the building performs

in accordance with these defined needs. The selection of a QA provider should include the same evaluation process the owner would use to select other team members. Qualifications in providing QA services, past performance of projects, cost of services, and availability of the candidate are some of the parameters an owner should investigate and consider when making a selection. Owners may select a member of the design or construction team as the QA provider. While there are exceptions, in general most designers are not comfortable operating and testing assemblies and equipment and most contractors do not have the technical background necessary to evaluate performance. Commissioning requires in-depth technical knowledge of the building envelope and the mechanical, electrical, and plumbing systems and operational and construction experience. This function is best performed by a third party responsible to the owner because political issues often inhibit a member of the design or construction organizations from fulfilling this responsibility.

QA3 *Owner's Project Requirements*

The Owner's Project Requirements (OPR) details the functional requirements of a project and the expectations of how the facility will be used and operated. This includes strategies and recommendations selected from this Guide (see Table 2-1 and Chapters 3 and 4) that will be incorporated into the project, anticipated hours of operation provided by the owner, and basis-of-design assumptions. The OPR forms the foundation of the team's tasks by defining project and design goals, measurable performance criteria, owner directives, budgets, schedules, and supporting information in a single, concise document. The QA process depends on a clear, concise, and comprehensive OPR.

Development of the OPR requires input from all key facility users and operators. The OPR evolves through each project phase and contains documented decisions made during the design, construction, occupancy, and operation phases. This becomes the primary document for recording success and quality at all phases of the project delivery and throughout the life of the facility. Included in the OPR are the designers' assumptions, which form the Basis of Design. The Basis of Design records the concepts, calculations, decisions, and product selections used to meet the OPR and to satisfy applicable regulatory requirements, standards, and guidelines.

Note: The OPR remains relatively fixed from its initial development until directed otherwise by the owner.

QA4 *Budgets Contained in the OPR*

The OPR is used to define the team's scope in both broad and specific terms. It also defines the QA scope and budgets. The effort and cost associated with designing and constructing an energy-efficient building can be and often are lost because the performance of systems is not verified.

QA5 *Design and Construction Schedule*

The inclusion of QA activities in the construction schedule fulfills a critical part of delivering a successful project. Identify the activities and time required for design review and performance verification to minimize time and effort needed to accomplish activities and correct deficiencies.

QA6 *Design Review*

A second pair of eyes provided by the CxA/QA provider gives a fresh perspective that allows identification of issues and opportunities to improve the quality of the construction documents with verification that the OPR is being met. Issues identified can be more easily corrected early in the project, providing potential savings in construction costs and reducing risk to the team. (See "Quality Assurance: In-House or Third Party?" and "Suggested Commissioning Scope" in Chapter 2 for more detail.)

QA7 *Defining Quality Assurance at Pre-Bid*

The building industry has traditionally delivered buildings without using a verification process. Changes in traditional design and construction procedures and practices require education of the construction team that explains how the QA process change will affect the various trades bidding the project. It is extremely important that the QA process be reviewed with the bidding contractors to facilitate understanding of and to help minimize fear associated with new practices. Teams who have participated in the Cx process typically appreciate the process because they are able to resolve problems while their manpower and materials are still on the project, significantly reducing delays, callbacks, and associated costs while enhancing their delivery capacity.

QA8 *Verifying Building Envelope Construction*

The building envelope is a key element of an energy-efficient design. Compromises in assembly performance are common and are caused by a variety of factors that can easily be avoided. Improper placement of insulation, improper sealing or lack of sealing around air barriers, wrong or poorly performing glazing and fenestration systems, incorrect placement of shading devices, misplacement of daylighting shelves, and misinterpretation of assembly details can significantly compromise the energy performance of the building (see “Cautions” sections throughout this chapter). The perceived value of the Cx process is that it is an extension of the quality control processes of the designer and contractor as the team works together to produce quality energy-efficient projects.

QA8A *Verifying Lighting Construction*

In warehouse buildings, lighting plays a significant role in the energy consumption of the building; its impact becomes more pronounced in conditioned warehouses located in cooling-dominated climates. Lighting for the office area will often be designed after construction of the shell. If possible, the lighting loads should be specified before selection of the HVAC systems in order to select the size and system type for the most efficient and cost-effective approach.

QA9 *Verifying Electrical and HVAC Systems Construction*

Performance of electrical and HVAC systems are key elements of this Guide. How systems are installed affects how efficiently they can be serviced and how well they will perform. Design reviews and construction observations identify problems when they are easy to correct.

QA10 *Testing*

Testing of systems is essential to ensuring that a project following this Guide will actually attain the energy savings that can be expected from the strategies and recommendations contained in this Guide (see “Suggested Commissioning Scope” in Chapter 2 for the CxA/QA provider responsibilities). If the contractors utilize the checklists as intended, testing of systems will occur quickly and only minor but important issues will need to be resolved to ensure that the building will perform as intended. Owners with operational and maintenance personnel can use the testing process as a training tool to educate their staff on how the systems operate as well as for system orientation. All system controls, such as lighting and HVAC controls, must be thoroughly tested to verify that the systems function as intended.

QA11 *Substantial Completion*

Substantial completion generally means the completion and acceptance of the life safety systems. Contractors, generally, have not completed the systems sufficiently at substantial completion to verify their performance. While the systems may be operational, they probably are not yet operating as intended. Expected performance can only be accomplished when all systems operate interactively to provide the desired results.

As contractors finish their work, they will identify and resolve many performance problems. The Cx/QA provider verifies that the contractor maintained a quality control process by directing and witnessing testing and then helps to resolve remaining issues.

QA12 *Maintenance Manual Submitted and Accepted*

The Cx/QA process includes communication of activities that the owner will be responsible for completing in order to maintain the manufacturers' warranties (see "Suggested Commissioning Scope" in Chapter 2 for QA provider responsibilities). A copy of the OPR should be provided to the O&M staff as a reference of the design intent along with an O&M manual that notes system modifications and/or operation for an understanding of how the building is intended to operate.

QA13 *Resolve Quality Control Issues Identified Throughout the Construction Phase*

Issues identified during the construction process are documented in an "issues log" and presented to the team for collaborative resolution. Issues are tracked and reviewed at progress meetings until they are resolved. Typically the CxA develops and maintains the issues log. Completion and acceptance of the systems and assemblies by the owner will be contingent upon what issues are still outstanding at the end of the project. Minor issues may be tracked by the owner's O&M staff, while other issues will require resolution before acceptance of the work. The Cx/QA process finishes with verification that the issues identified have been resolved. The owner provides direction to the team to resolve issues identified.

QA14 *Final Acceptance*

Final acceptance generally occurs after the Cx/QA issues in the issues log have been resolved, except for minor issues the owner is comfortable with resolving during the warranty period.

QA15 *Establish Building Maintenance Program*

Continued performance and control of O&M costs require a maintenance program. The O&M manuals provide information that the O&M staff uses to develop this program. Detailed O&M system manual and training requirements are defined in the OPR and executed by the project team to ensure the O&M staff has the tools and skills necessary. The level of expertise typically associated with O&M staff for buildings covered by this Guide is generally much lower than that of a degreed or accredited engineer, and they typically need assistance with development of a preventive maintenance program. The Cx/QA provider can help bridge the knowledge gaps of the O&M staff and assist the owner with developing a program that would help ensure continued performance. The benefits associated with energy-efficient buildings are realized when systems perform as intended through proper design, construction, operation, and maintenance.

QA16 *Monitor Post-Occupancy Performance*

Establishing measurement and verification procedures with a performance baseline from actual building performance after it has been commissioned can identify when corrective action and/or repair is required to maintain energy performance. Utility consumption and factors affecting utility consumption should be monitored and recorded to establish building performance during the first year of operation.

Variations in utility usage can be justified based on changes in conditions typically affecting energy use, such as weather, occupancy, operational schedule, maintenance procedures, and equipment operations required by these conditions. While most buildings covered in this Guide will not use a formal measurement and verification process, tracking the specific parameters listed above does allow the owner to quickly review utility bills and changes in conditions. Poor performance is generally obvious to the reviewer when comparing the various parameters. CxA/QA providers can typically help

owners understand when operational tolerances are exceeded and can provide assistance in defining what actions may be required to return the building to peak performance.

ENVELOPE

Opaque Envelope Components

Good Design Practice

EN1 *Conditioned and Semi-Heated Spaces (Climate Zones: all)*

As defined in this Guide, a conditioned space is both heated and cooled to maintain human comfort conditions and applies to offices and fine storage areas. A semi-heated space is only heated to 45°F and applies to bulk storage areas.

EN2 *Cool Roofs (Climate Zones: 1 2 3)*

In order to be considered a cool roof, a solar reflectance index (SRI) of 78 or higher is recommended. A high reflectance keeps much of the sun's energy from being absorbed, while a high thermal emittance radiates away any solar energy that is absorbed, allowing the roof to cool more rapidly. Cool roofs are typically white and have a smooth surface. Commercial roof products that qualify as cool roofs fall into three categories: single-ply, liquid-applied, and metal panels. Examples are presented in Table 5-1.

The solar reflectance and thermal emittance property values represent initial conditions as determined by a laboratory accredited by the Cool Roof Rating Council.

An SRI can be determined by the following equations:

$$\text{SRI} = 123.97 - 141.35(\chi) + 9.655(\chi^2)$$

where

$$\chi = \frac{20.797 \times \alpha - 0.603 \times \varepsilon}{9.5205 \times \varepsilon + 12.0}$$

where α is the solar absorptance ($= 1 - \text{solar reflectance}$) and ε is the thermal emissivity, which were derived from ASTM E1980 assuming a medium wind speed.

Table 5-1. Examples of Cool Roofs

Category	Product	Reflectance	Emissivity	SRI
Single-ply	White polyvinyl chloride (PVC)	0.86	0.86	107
Single-ply	White chlorinated polyethylene (CPE)	0.86	0.88	108
Single-ply	White chlorosulfonated polyethylene (CPSE), e.g., Hypalon	0.85	0.87	106
Single-ply	White thermoplastic polyolefin (TSO)	0.77	0.87	95
Liquid-applied	White elastomeric, polyurethane, acrylic coating	0.71	0.86	86
Liquid-applied	White paint (on metal or concrete)	0.71	0.85	86
Metal panels	Factory-coated white finish	0.70	0.87	85

EN3 Roofs, Insulation Entirely above Deck (Climate Zones: all)

The insulation entirely above deck (see Figure 5-1) should be continuous insulation (c.i.) rigid boards because there are no framing members present that would introduce thermal bridges or short circuits to bypass the insulation.

When two layers of c.i. are used in this construction, the board edges should be staggered

to reduce the potential for convection losses or thermal bridging. If an inverted or protected membrane roof system is used, at least one layer of insulation is placed above the membrane while a maximum of one layer is placed beneath the membrane.

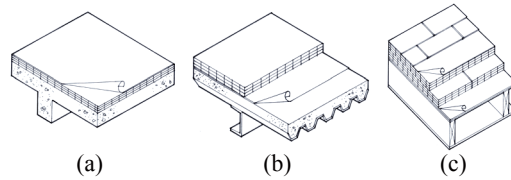

Figure 5-1. (EN3) Insulation entirely above deck—insulation is installed above (a) concrete, (b) metal, or (c) wood deck in a continuous manner.

EN4 Roofs, Metal Buildings (Climate Zones: all)

In metal building roof construction, purlins are typically z-shaped cold-formed steel members, although open web steel joists are sometimes used for longer spans.

The thermal performance of metal building roofs with fiberglass blankets is improved by addressing the thermal bridging associated with compression at the purlins. The two types of metal building roofs are standing seam roofs and through-fastened roofs. Standing seam roofs have very few exposed fasteners and utilize a concealed clip for the structural attachment of the metal roof panel to the purlins. The larger gap between the purlin and the roof panels, along with the thermal spacer block, provides a thermal break that results in improved performance compared to the standard through-fastened metal roofs. It is recommended that the thermal resistance between the purlin and the metal deck be at least R-8. One means to accomplish this is by using a $3/4 \times 3$ in. foam block (R-5) over $3/4$ in. of compressed fiberglass blanket (R-3) (see Figure 5-2). Alternatively, a 2 in. space filled with compressed fiberglass insulation will provide roughly R-8.

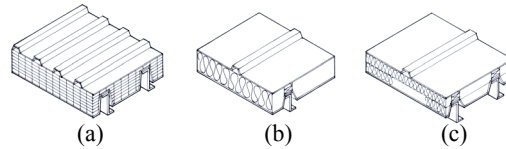

Figure 5-2. (EN4) Prefabricated metal roofs showing thermal blocking of purlins.

Through-fastened metal roofs are screwed directly to the purlins and have fasteners that are exposed to the elements. The fasteners have integrated neoprene washers under the heads to provide a weathertight seal. Thermal spacer blocks are not used with through-fastened roofs because they may diminish the structural load-carrying capacity by “softening” the connection and restraint provided to the purlin by the metal roof panels. To meet some of the performance recommendations of this Guide, through-fastened roofs will generally require insulation over the purlins in the conventional manner, with a second layer of insulation added to the system. The second layer of insulation can be placed either parallel to the purlins (on top of the first layer) or suspended below the purlins.

In climate zone 1, the recommended construction is standing-seam roofs with one layer of an insulation blanket draped over the purlins.

In climate zones 2 through 7, the recommended construction is standing-seam roofs with two layers of blanket insulation. The first layer is draped perpendicularly over the purlins with enough looseness to allow the second insulation layer to be laid above it, parallel to the purlins.

In climate zone 8, the recommended construction is a filled cavity insulation system, herein called a *liner system*.

In any case, rigid c.i. or other high-performance insulation systems may be used provided the total roof assembly has a U-factor that is less than or equal to the appropriate climate zone construction listed in Appendix A.

EN5 Roofs, Single Rafter (Climate Zones: all)

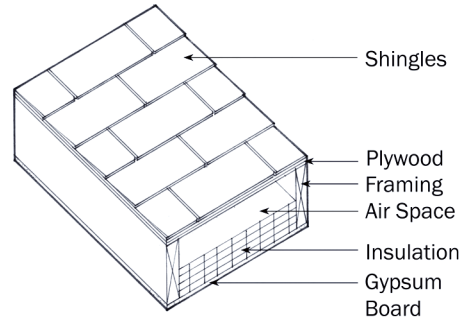

Figure 5-3. (EN5) Wood joists, single rafter.

The cavity insulation should be installed between the wood rafters and in intimate contact with the ceiling to avoid the potential thermal short-circuiting associated with open or exposed air spaces.

Single rafter roofs have the roof above and ceiling below both attached to the same wood rafter, and the cavity insulation is located between the wood rafters (see Figure 5-3). Continuous insulation, when recommended, is installed to the bottom of the rafters and above the ceiling material. Single rafters can be constructed using solid wood framing members or truss type framing members. The

EN6 Walls, Mass (Climate Zones: all)

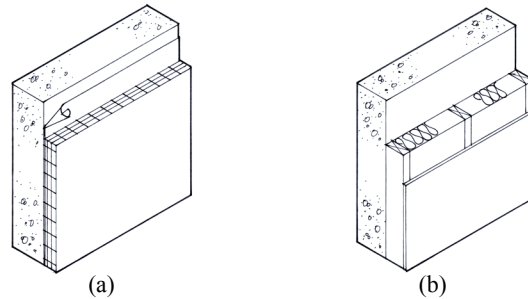

Figure 5-4. (EN6) Walls, mass—any concrete or mass wall with a heat capacity exceeding 7 Btu/ft²·°F.

Mass walls are defined as those with a heat capacity exceeding 7 Btu/ft²·°F. Insulation may be placed on either the inside or the outside of the mass wall. When insulation is placed (a) on the exterior of the wall, rigid c.i. is recommended (see Figure 5-4); when insulation is placed (b) on the interior of the wall, a furring or framing system may be used, provided the total wall assembly has a U-factor that is less than or equal to the appropriate climate zone construction listed in Appendix A.

The greatest advantages of mass can be obtained when insulation is placed on the exterior of the mass. In this case, the mass absorbs internal heat gains that are later released in the evenings when the buildings are not occupied.

EN7 Walls, Metal Building (Climate Zones: all)

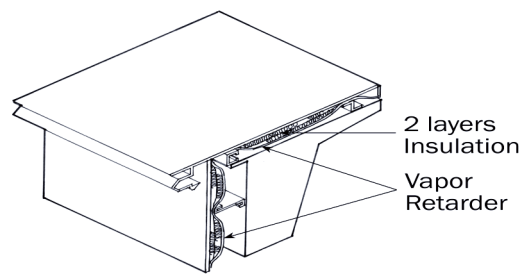

Figure 5-5. (EN7) Walls, metal building.

In climate zones where a single layer of fiberglass batt insulation is recommended, the insulation is installed continuously perpendicular to the exterior of the girts and is compressed as the metal panel is attached to the girts (see Figure 5-5). In climate zones where a layer of faced fiberglass batt insulation and a layer of rigid board

insulation are recommended, the layer of fiberglass is installed continuously perpendicular to the exterior of the girts and is compressed as the rigid board insulation is installed continuously and perpendicular then attached to the girts from the exterior (on top of the fiberglass). The metal panels are then attached over the rigid board insulation using screws that penetrate through the insulation assembly into the girts.

In all climate zones, rigid c.i. is another option provided the total wall assembly has a U-factor that is less than or equal to the appropriate climate zone construction listed in Appendix A.

EN8 Walls, Steel Framed (Climate Zones: all)

Cold-formed steel framing members are thermal bridges to the cavity insulation (see Figure 5-6). Batt insulation, when installed in cold-formed steel-framed wall assemblies, is to be ordered as “full width batts,” and installation is normally by friction fit. Adding exterior foam sheathing as c.i. is the preferred method to upgrade the wall thermal performance because it will increase the overall wall thermal performance and tends to minimize the impact of the thermal bridging.

Alternative combinations of cavity insulation and sheathing in thicker steel-framed walls can be used provided that the proposed total wall assembly has a U-factor that is less than or equal to the U-factor for the appropriate climate zone construction listed in Appendix A.

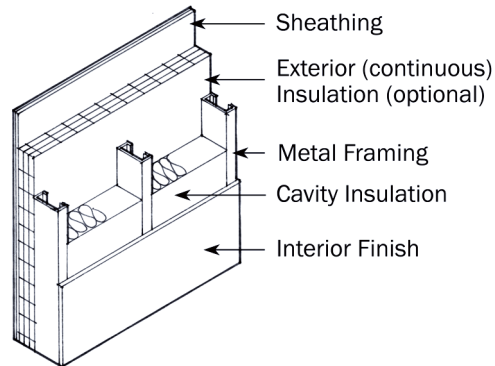

Figure 5-6. (EN8) Walls, steel framed—a common construction type in nonresidential buildings.

EN9 Walls, Wood Frame and Other (Climate Zones: all)

Cavity insulation is used within the wood-frame wall, while rigid c.i. is placed on the exterior side of the framing (see Figure 5-7). Care must be taken to have a vapor retarder on the warm side of the wall and to utilize a vapor-retarder-faced batt insulation product to avoid insulation sagging away from the vapor retarder.

Alternative combinations of cavity insulations and sheathings in thicker walls can be used provided the total wall assembly has a U-factor that is less than or equal to the appropriate climate zone construction listed in Appendix A.

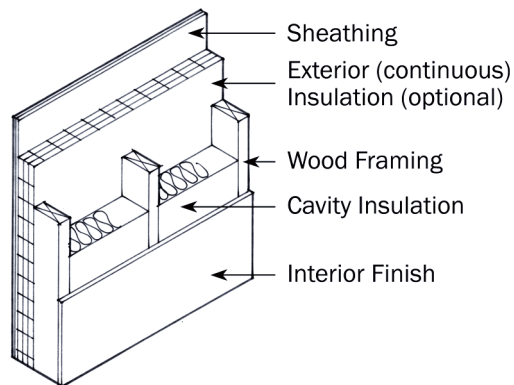

Figure 5-7. (EN9) Walls, wood frame and other.

EN10 Slab-on-Grade Floors, Unheated (Climate Zones: 6 7 8)

Figure 5-8. (EN10) Slab-on-grade floors, unheated—no heating elements either within or below the slab.

As shown in Figure 5-8, (a) rigid c.i. should be used around the perimeter of the slab and should reach the depth listed in the recommendation or to the bottom of the footing, whichever is less; (b) additionally, in climate zones 6–8 and in cases where the frost line is deeper than the footing, c.i. should be placed beneath the slab as well.

EN11 Doors, Opaque and Swinging (Climate Zones: all)

Figure 5-9. (EN11) Doors, swinging—opaque doors.

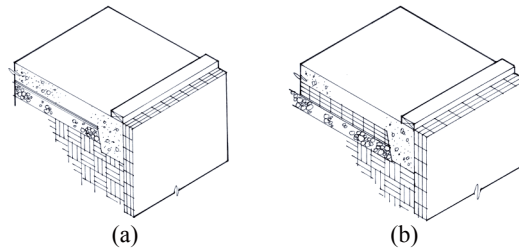
A U-factor of 0.37 corresponds to an insulated double-panel metal door. A U-factor of 0.61 corresponds to a double-panel metal door. If at all possible, single swinging doors should be used. Double swinging doors are difficult to seal at the center of the doors (see Figure 5-9) unless there is a center post. Double swinging doors without a center post should be minimized and limited to areas where width is important. Vestibules can be added to further improve the energy efficiency.

EN12 Doors, Opaque and Roll-Up or Sliding (Climate Zones: all)

Roll-up or sliding doors are recommended to have R-4.75 rigid insulation or meet the recommended U-factor. When meeting the recommended U-factor, the thermal bridging at the door and section edges is to be included in the analysis. Roll-up doors that have solar exposure should be painted with a reflective paint (or high emissivity) and/or should be shaded. The issue with metal doors is that they typically have poor emissivity and collect heat, which is transmitted through even the best insulated door, causing cooling loads and thermal comfort issues in the space.

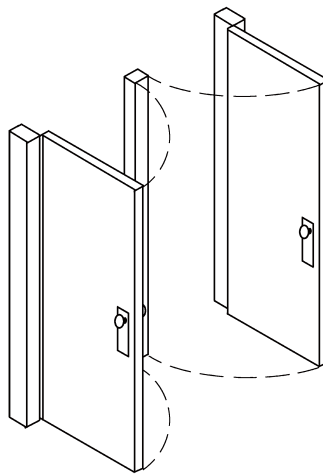
If at all possible, use insulated panel doors over roll-up doors, as the insulation values can approach R-10 and provide a tighter seal to minimize infiltration.

EN13 Alternative Constructions (Climate Zones: all)

Infiltration through loading dock doors when open for truck loading or unloading can result in significant energy consumption. ASHRAE/IESNA Standard 90.1 requires that loading dock doors be equipped with weatherseals to restrict infiltration when the doors are open and trailers are in place. Dock seals or shelters should conform closely to the sides and top of the trailer to minimize the area of opening for infiltration. Two additional apertures—the dock leveler operating clearance and the hinge gap of the trailer doors—are not covered by this standard. Dock levelers should be furnished with brush-type seals to reduce the effective leakage crack width of the operating clearance from approximately 1.125 in. to less than 0.25 in. Inflatable or foam-type hinge seals should be utilized to minimize infiltration through this gap.

Cautions

The design of building envelopes for durability, indoor environmental quality, and energy conservation should not create conditions of accelerated deterioration, reduced thermal performance, or problems associated with moisture and air infiltration. The following cautions should be incorporated into the design and construction of the building.

EN14 *Slab Edge Insulation (Climate Zones: all)*

Use of slab-edge insulation improves thermal performance, but problems can occur in regions of the country that have termites.

EN15 *Moisture Control (Climate Zones: all)*

Building envelope assemblies (see Figures 5-10a and 5-10b) should be designed to prevent wetting, high moisture content, liquid water intrusion, and condensation caused by diffusion of water vapor. See *ASHRAE Handbook—Fundamentals*, Chapter 24, for additional information.

EN16 *Air Infiltration Control (Climate Zones: all)*

The building envelope should be designed and constructed with a continuous air barrier system to control air leakage into or out of the conditioned space. An air barrier system should also be provided for interior separations between conditioned space and space designed to maintain temperature or humidity levels that differ from those in the conditioned space by more than 50% of the difference between the conditioned space and design ambient conditions. The air barrier system should have the following characteristics:

- It should be continuous, with all joints made airtight.
- Air barrier materials used in frame walls should have an air permeability not to exceed 0.004 cfm/ft² under a pressure differential of 0.3 in. water (1.57 lb/ft²) when tested in accordance with ASTM E 2178.
- The system is capable of withstanding positive and negative combined design wind, fan, and stack pressures on the envelope without damage or displacement and should transfer the load to the structure. It should not displace adjacent materials under full load.
- It is durable or maintainable.
- The air barrier material of an envelope assembly should be joined in an airtight and flexible manner to the air barrier material of adjacent assemblies, allowing for the relative movement of these assemblies and components due to thermal and moisture variations, creep, and structural deflection.
- Connections should be made between:
 - a. Foundation and walls
 - b. Walls and windows or doors
 - c. Different wall systems
 - d. Wall and roof
 - e. Wall and roof over unconditioned space
 - f. Walls, floors, and roof across construction, control, and expansion joints
 - g. Walls, floors, and roof to utility, pipe, and duct penetrations
- All penetrations of the air barrier system and paths of air infiltration/exfiltration should be made airtight.

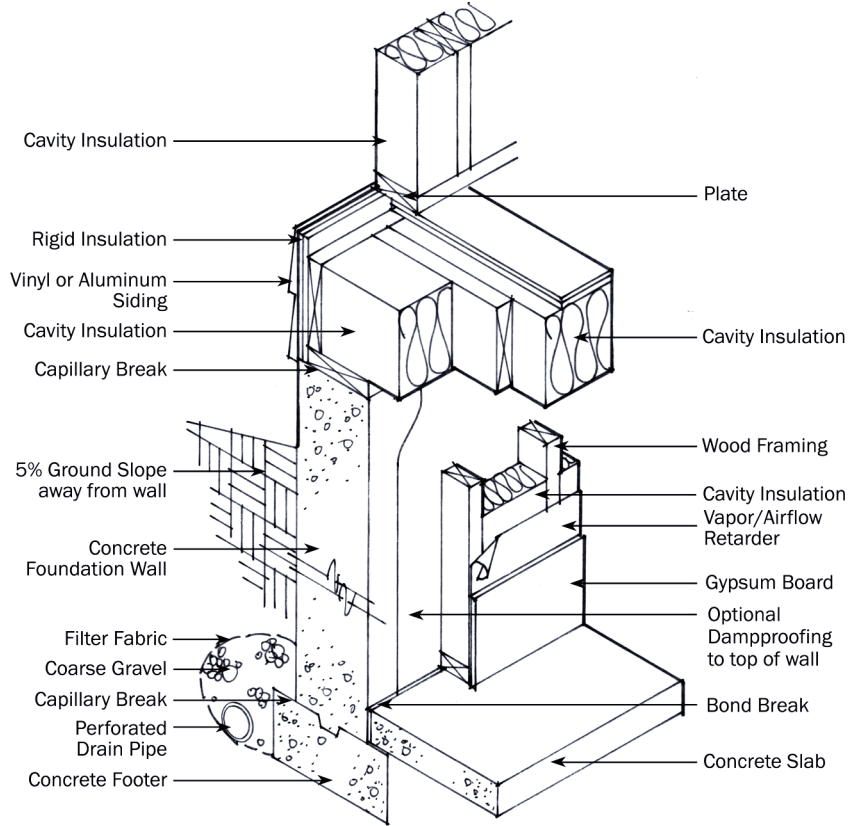

Figure 5-10a. (EN15) Moisture control for mixed climates.

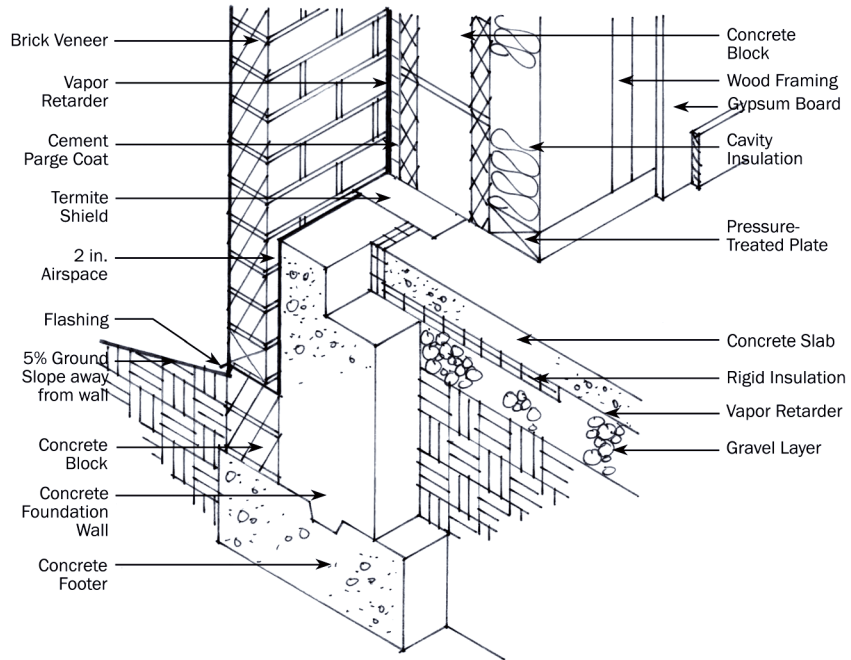

Figure 5-10b. (EN15) Moisture control for warm, humid climates.

Fenestration: Vertical Glazing and Skylights (Envelope)

Good Design Practice

EN17 General (Climate Zones: all)

The recommendations for fenestration are subdivided into those for vertical glazing (e.g., storefront windows, glazed doors, other windows) and those for skylights and are listed in Chapter 3 by climate zone. Vertical fenestration is defined as a slope greater than 60° from the horizontal (see Figure 5-11).

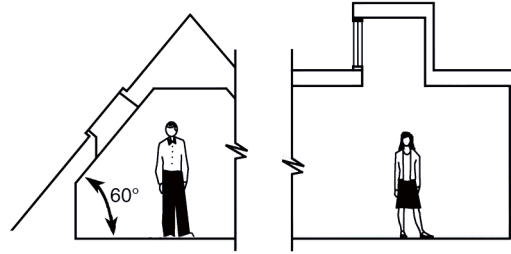

Figure 5-11. (EN17) Vertical fenestration—defined as slope greater than 60° from the horizontal.

Table 5-2 lists the type of vertical glazing construction that generally corresponds to the U-factors and solar heat gain coefficient (SHGC) values in the Chapter 3 Recommendation Tables.

To be useful and consistent, the U-factors should be measured over the entire fenestration assembly, not just the center of glass. Look for a National Fenestration Rating Council (NFRC) label (or NFRC Label Certificate for site-built fenestration) that denotes the fenestration product is rated, certified, and labeled in accordance with NFRC procedures. The selection of high-performance window products should be considered separately for each orientation of the building and for daylighting and viewing functions.

EN18 Skylight Area as a Percentage of Gross Roof Area (Climate Zones: 1 2 3 4 5 6 7)

This is the percentage resulting from dividing the total skylight product area of the building by the gross roof area. Five to seven percent of the gross roof area is required to be skylights in order to achieve a yearly lighting energy savings of at least 50%. A smaller skylight area may be used if a computer simulation shows the minimum 50% yearly savings is met. Skylights provide increased daylight along with a reduction in lighting energy consumption at the expense of increasing cooling loads in warmer climates and increasing heating loads in cooler climates. To achieve the lighting energy savings, all lighting fixtures within the daylight zone must have automatic controls that dim or multi-level switch the lighting in response to available daylight. (See DL4 and DL7 for guidance.)

Table 5-2. Vertical Fenestration Descriptions

U-Factor	SHGC	VLT	Description
0.56	0.25	0.30	Double glazing; clear glass; metal frame; high-performance tint; medium-performance reflective
0.45	0.25	0.32	Double glazing; clear glass; metal frame with a thermal break; high-performance tint; medium-performance reflective
0.42	0.40	0.55	Double glazing; clear glass; metal frame with a thermal break; super sputter low-e (e = 0.05) on both panes
0.33	0.45	0.60	Double glazing; clear glass; vinyl/insulated frame; super sputter low-e (e = 0.05) on both panes

EN19 Skylight Design (Climate Zones: 1 2 3 4 5 6 7)

Skylights need to let diffuse daylight into the space, not direct sunlight. Skylights must meet the thermal transmittance and SHGC values listed in the recommendation tables of Chapter 3. For daylight harvesting, the visible light transmittance (VLT) must be at least 45% and the glazing material or diffuser should have a minimum haze value of at least 90% as measured according to ASTM D1003. Skylights also must incorporate fall protection and internal gutters to collect and dispose of condensation. The parameters for skylight design are:

- Condensate gutter or other method that captures condensate from skylight glazing.
- VLT at least 45%; U-factor as recommended in Chapter 3.
- Haze as measured according to ASTM D1003 of at least 90%.
- General lighting in skylighted area controlled by multi-level (including continuous dimming) photocontrols.
- Fall protection required—most reliable form is burglar bars or mesh in curb or light well. Plastic skylights rated to comply with Occupational Safety and Health Administration (OSHA) fall protection may not provide adequate protection as the plastic ages.

EN20 Fenestration Design Guidelines for Thermal Conditions (Climate Zones: all)

Uncontrolled solar heat gain is a major cause of energy consumption for cooling and thermal discomfort for occupants. These problems can be significantly reduced with an appropriate configuration of vertical glazing according to the orientation of the wall on which they are placed and by not exceeding the recommended skylight area percentage.

EN21 Solar Heat Gain is Most Effectively Controlled on the Outside of the Building (Climate Zones: all)

Figure 5-12. (EN21) Windows with overhang.

Significantly greater energy savings are realized when sun penetration is blocked before entering the windows. Horizontal overhangs located at the top of the windows are most effective for south-facing façades and must continue beyond the width of the windows to adequately shade them. In predominantly sunny climates the overhang should be totally opaque, while in predominantly cloudy climates the overhang should be translucent. The vertical extension of the overhang depends on the height of the overhang from the bottom of the window sill (see Figure 5-12). *Note:* Overhangs located directly above the window head need the least projection.

*(EN21 continues
on next page)*

Vertical fins oriented slightly north are most effective for east- and west-facing façades (see Figure 5-13). Consider louvered or perforated sun control devices, especially in primarily overcast and colder climates, to prevent a totally dark appearance in those environments.

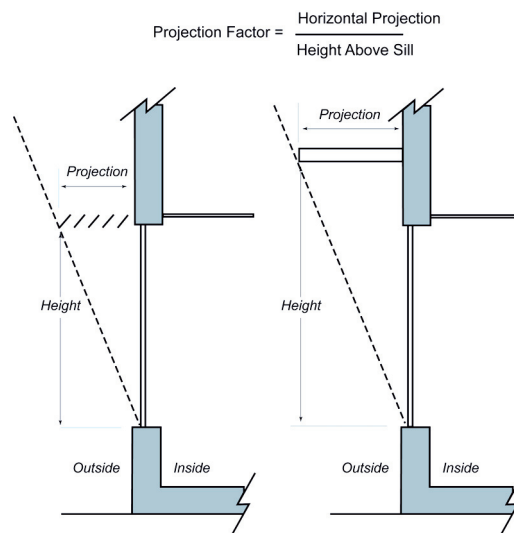
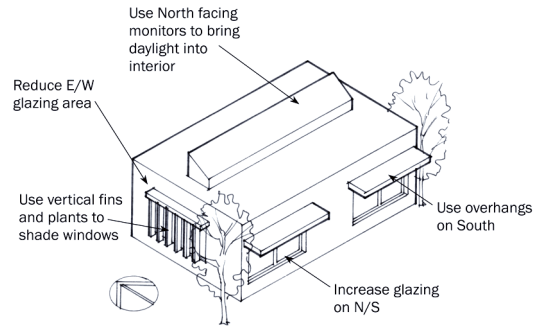

Figure 5-13. (EN21) Exterior sun control.

EN22 Operable versus Fixed Windows (Climate Zones: all)

Operable windows offer the advantage of personal comfort control and beneficial connections to the environment. However, individual operation of the windows not in coordination with the HVAC system settings and requirements can have impacts on the energy use of a building's system. Advanced energy buildings with operable windows should strive for a high level of integration between envelope and HVAC system design. First, the envelope should be designed to take advantage of natural ventilation with well-placed operable openings. Second, the mechanical system should employ interlocks on operable windows to ensure that the HVAC system responds by shutting down in the affected zone if the window is opened. It is important to design the window interlock zones to correspond as closely as possible to the HVAC zone affected by the open window.

EN23 Building Form and Window Orientation (Climate Zones: all)

In all climates, north- and south-facing glass can be more easily shielded and can result in less solar heat gain and less glare than can east- and west-facing glass. During site selection, preference should be given to sites that permit locating office areas along south or north sides of the building.

A good design strategy avoids glass that does not contribute to views or the daylighting of the space. Since sun control devices are less effective on the east and west façades, the solar penetration through the east- and west-facing glazing can cause a problem with glare and heat gain. This can be done by reducing the area of glazing, reducing the SHGC, or preferably both.

Warm Climates

EN24 Glazing (Climate Zones: 1 2 3 4)

For north- and south-facing windows, select windows with a low SHGC and an appropriate VLT. Certain window coatings, called *selective low-e*, transmit the visible portions of the solar spectrum selectively, rejecting the nonvisible infrared sections. These glass and coating selections provide superior view and daylighting while minimizing solar heat gain. Window manufacturers market special “solar low-e” windows for warm climates. All values are for the entire fenestration assembly, in compliance with NFRC procedures, and are not simply center-of-glass values. For warm climates, a low SHGC is much more important for low building energy consumption than the window assembly U-factor. Windows with low SHGC values will tend to have a low center-of-glass U-factor, however, because they are designed to reduce the conduction of the solar heat gain absorbed on the outer light of glass through to the inside of the window.

EN25 Glazing (Climate Zones: 5 6 7 8)

For more northerly locations, only the south-facing glass receives much sunlight during the cold winter months. If possible, maximize south-facing office windows by placing the office areas on the south side of the warehouse. Be careful to install blinds or other sun-control devices for south-facing glass to allow for passive effects when desired but prevent unwanted glare and solar overheating. Glass facing east and west should be significantly limited. Areas of glazing facing north should be cautiously sized for daylighting and view. (See DL3 for additional information.) Although higher SHGCs are allowed in colder climate zones, continuous horizontal overhangs are still useful for blocking summer sun. Window manufacturers market low-e glazing with higher SHGCs for cold climates.

EN26 Obstructions and Planting (Climate Zones: all)

Adjacent taller buildings and trees, shrubs, or other plantings are effective for shading glass on south, east, and west facades. For south-facing windows, remember that the sun is higher in the sky during the summer, so shading plants should be located high above the windows to effectively shade the glass. The glazing of fully shaded windows can be selected with higher SHGC ratings without increasing energy consumption. The solar reflections from adjacent buildings with reflective surfaces (metal, windows, or especially reflective curtain walls) should be considered in the design. Such reflections may modify shading strategies, especially on the north façade.

EN27 Passive Solar (Climate Zones: all)

Passive solar energy-saving strategies should be limited to lobbies and circulation areas. Consider heat-absorbing blinds in cold climates or reflective blinds in warm climates. In spaces where glare is not an issue, the usefulness of the solar heat gain collected by windows can be increased by using massive thermally conductive floor surfaces, such as tile or concrete, in locations where the transmitted sunlight will fall. These floor surfaces absorb the transmitted solar heat gain and release it slowly over time to provide a more gradual heating of the structure. Consider low-e glazing with exterior overhangs.

References

- ASHRAE. 2005. *ASHRAE Handbook—Fundamentals*. Chapter 24, Thermal and moisture control in insulated assemblies—Applications. Atlanta: American Society of Heating, Refrigerating and Air-Conditioning Engineers, Inc.
- ASHRAE. 2007. *ANSI/ASHRAE/IESNA Standard 90.1-2007, Energy Standard for Buildings Except Low-Rise Residential Buildings*. Atlanta: American Society of Heating, Refrigerating and Air-Conditioning Engineers, Inc.
- ASTM. 2001. *ASTM E 1980, Standard Practice for Calculating Solar Reflectance Index of Horizontal and Low-Sloped Opaque Surfaces*. West Conshohocken, PA: American Society for Testing and Materials.
- ASTM. 2003. *ASTM E 2178, Standard Test Method for Air Permeance of Building Materials*. West Conshohocken, PA: American Society for Testing and Materials.
- IESNA. 1997. *EPRI Daylight Design: Smart and Simple*. New York: Illuminating Engineering Society of North America.
- LBL. 1997. Tips for daylighting with windows. *Windows & Daylighting*. Berkeley, CA: Lawrence Berkeley National Laboratories. <http://windows.lbl.gov/daylighting/designguide/designguide.html>.
- Evans, Benjamin. 1997. *Daylighting Design, Time Saver Standards for Architectural Design Data*. New York: McGraw-Hill.

LIGHTING

The goals for the lighting section of the AEDG-WHSE are to optimize daylighting in the warehouse spaces to minimize the need for electric lighting during daylight hours while providing good vertical illumination on the stacks. The most effective way to bring daylight into the space is by using toplighting (skylights). The electric lighting, in turn, must respond to the changing daylight and automatically reduce its power to save energy. While it is easy to measure footcandles at the floor, the main task surface is vertical. Therefore, both the daylighting and the electric lighting need to provide good illumination on the face of the racking and into storage areas. This is difficult to accomplish by point-source electric lights and skylights spaced more than 1.4 times the ceiling height apart.

Daylighting

Good Design Practice

DL1 Savings and Occupant Acceptance (Climate Zones: all)

Daylight in warehouses can save energy if the electric lighting is switched or dimmed in response to changes in daylight levels. Automatic lighting controls increase the probability that daylighting will save energy. It is also important that heat gain and loss through glazing is controlled in conditioned spaces. In addition, glare and contrast must be controlled so occupants are comfortable and will not override electric lighting controls. (See additional comments related to skylight design and placement in EN18 and EN19.)

DL2 Surface Reflectance (Climate Zones: all)

The use of light-colored materials and matte finishes in all daylighted spaces increases efficiency through interreflections and greatly increases visual comfort. (See EL2.)

DL3 Control of Direct Sun Penetration (Climate Zones: all)

Daylighting utilizes light from the sky, not the direct sun. Patches of direct sunlight in the warehouse and office areas will create unacceptable brightness and excessive contrast between light and dark areas.

Use exterior and interior sun control devices. Exterior sun control and overhangs help reduce both direct sun penetration and heat gain from vertical glazing surfaces.

In office areas:

- Use continuous exterior overhangs and interior horizontal blinds or shades on south-facing glazing.
- Use interior vertical slat blinds or shades on east- and west-facing glazing and as required for northeast or northwest façades.
- An exterior overhang needs to be deep enough to shield windows above the light shelf (if used) from direct sun. The light shelf, or the overhang if the light shelf is not used, should also be deep enough to shield windows below the shelf from direct sun.

In warehouse areas (see EN19 for additional skylight design recommendations):

- For skylights, use prismatic diffusing glazing to control direct sun.
- Alternately, use north-facing clerestories to avoid direct sun.

DL4 Skylight Layout (Climate Zones: 1 2 3 4 5 6 7)

In warehouse spaces with tall racking, it is critical to lay out the skylights to match the anticipated aisle spacing with skylights in the center of each aisle.

Install prismatic diffusing skylights to meet 5%–7% of the floor to achieve a yearly lighting energy savings of at least 50%. A lower skylight area may be used if a computer simulation shows the minimum 50% yearly savings is met.

Do not space skylights more than 1.4 times the ceiling height apart to maintain even daylight illumination. The daylighted area is the outline of the opening beneath the skylight plus 70% of the ceiling height in each horizontal direction. (See DL7.)

Use smaller-aperture skylights in a grid pattern to gain maximum usable daylight with the least thermal heat transfer.

DL5 Skylight Thermal Transmittance (Climate Zones: 1 2 3 4 5 6 7)

As an alternative to skylights, use clerestories for skylighting. Never use east- or west-facing clerestories due to excessive summer heat gain and the difficulty of controlling direct sunlight. Clerestories with operable glazing may also help provide natural ventilation in temperate seasons. Typically, north-facing clerestories have 1/6 the heat gain of skylights but provide less than 1/3 the daylighting potential per square foot of prismatic skylights.

Shade south-facing clerestories and skylights with exterior/interior sun control such as screens, baffles, or fins. (See DL3.)

Insulate the skylight curb above the roof line with rigid c.i. in conditioned spaces.

Hot Climates

- Use skylights or north-facing clerestories for skylighting to eliminate excessive solar heat gain and glare.
- Reduce thermal gain during the cooling season by using skylights with a low overall thermal transmittance (U-factor).

Moderate and Cooler Climates

- Use skylights or either north- or south-facing clerestories for skylighting to eliminate excessive solar heat gain and glare.
- Reduce summer heat gain as well as winter heat loss by using skylights with a low overall thermal transmittance. Use a skylight frame that has a thermal break to prevent excessive heat loss/gain and winter moisture condensation on the frame.

DL6 Interactions (Climate Zones: 1 2 3 4 5 6 7)

Figure 5-14. (DL6) Skylight (horizontal fenestration).

Thermal gains and losses associated with skylights should be balanced with daylight-related savings achieved by reducing electric lighting consumption.

Skylight well height (side walls below the skylight) should be as short as possible. If skylight well is over 2 ft high, splay skylight opening at 45° to maximize daylight distribution and minimize glare (see Figure 5-14).

Ceiling reflectance values should be a minimum of 80% to reduce contrast between skylight and ceiling.

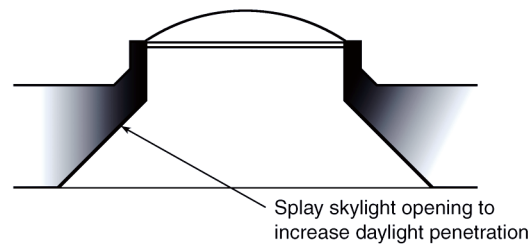
DL7 Expanded Recommendations for Electric Lighting Controls in Daylight Zone (Climate Zones: all)

The *daylight zone* for skylights is the area of the skylight plus 70% of the floor-to-ceiling dimension in all directions from the edge of the skylight (see Figure 5-15).

The *daylight zone* for windows is:

- depth = the distance from the exterior windows equal to the head height of the windows
- width = the width of the windows plus 2 ft on each side of the window

Automatic daylight harvesting controls. In warehouse areas, continuously dim or switch electric lights in response to daylight. Control luminaires in groups around skylights, and when daylight zones overlap a single control zone may be used. The daylighting control system and/or photo-sensor should include a five-minute time delay or other means to avoid cycling caused by rapidly changing sky conditions and a one-minute fade rate to change the light levels by dimming.

Dimming controls. Specify dimming ballasts that dim down to at least 20% of full output. Photosensors should include a one-minute fade rate to change the light levels by dimming and must achieve a slow, smooth, linear response. New lamps must be operated at full light output for 100 hours or per manufacturer recommendation prior to dimming. Follow the manufacturer's recommendations for setup and calibration setting.

Switching controls. Specify luminaires with two-lamp tandem wired ballasts and circuit switch legs to luminaires capable of multilevel daylight control to provide 100%/50%/0% or 100%/66%/33%/0% light levels. Follow control manufacturer's recommendations for setup and calibration setting of photo-controls.

DL8 Photosensor Placement (Climate Zones: all)

Photosensors used should be specified for indoor illuminance range.

Open-loop photosensors are best used in the warehouse spaces. The best location for the photosensor is inside the skylight well. An open-loop system is one in which the photocell responds only to daylight levels but is still calibrated to the desired light level received on the floor of the warehouse. Photosensors in warehouse high rack areas must be calibrated separately from photosensors in open areas.

Closed-loop photosensors are best used in office spaces. A closed-loop system is one in which the interior photocell responds to the combination of daylight and electric light in the area. The best location for the photocell is above an unobstructed location such as a circulation path. If using a lighting system that provides an indirect component, mount the photosensor at the same height as the luminaire or in a location that is not impacted by the uplight from the luminaire.

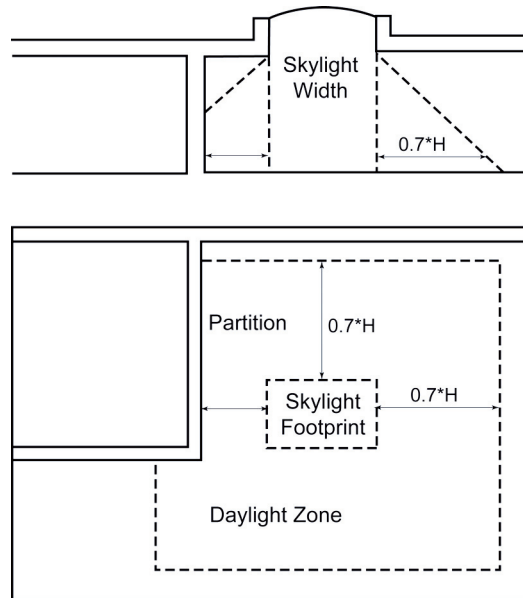

Figure 5-15. (DL7) Daylight zone under skylight.

DL9 Calibration and Commissioning (Climate Zones: all)

Even a few days of occupancy with poorly calibrated controls can lead to permanent overriding of the system and loss of all savings. All lighting controls must be calibrated and commissioned after the finishes are completed and the racking and products are in place. Locate photo-controls so that calibration and setpoint adjustment controls are easily accessible. Follow manufacturers' recommendations for setup and calibration setting (most photosensors require daytime and nighttime calibration sessions). The photosensor manufacturer and the QA provider should be involved in the calibration. Document the calibration and Cx settings and calendar intervals for future recalibration. Systems should be checked for proper calibration and operation at least every two years.

DL10 Daylight Levels (Climate Zones: all)

Occupants expect higher combined light levels in daylighted spaces. Consequently, it is more acceptable to occupants when the electric lights are calibrated to dim or switch when the combined daylight and electric lighting exceeds 1.20 times the designed light level; i.e., if the ambient electric light level is designed for 30 maintained footcandles, the electric lights should begin to dim when the combined level is 36 footcandles ($30 \times 1.20 = 36$). When using daylight switching, the electric lights should step down only when the initial designed light level is maintained after the step down.

References

- IESNA. 1996. *EPRI Lighting Controls—Patterns for Design*. New York: Illuminating Engineering Society of North America.
- IESNA. 1997. *EPRI Daylighting Design: Smart and Simple*. New York: Illuminating Engineering Society of North America.
- DLC. 2008. *Warehouse Skylighting knowhow™ Design Guide*. DesignLights™ Consortium. www.designlights.org/guides.html.
- NBI. 2003. *Advanced Lighting Guidelines*. White Salmon, WA: New Buildings Institute. www.newbuildings.org/lighting.htm.
- NLPIP. 2008. Photosensor tutorial. National Lighting Product Information Program, Rensselaer Polytechnic Institute, Troy, NY. www.lrc.rpi.edu/programs/NLPIP/tutorials/photosensors.

Electric Lighting Design*Interior Electric Lighting***Good Design Practice**

For this Guide, the warehouse is divided into “bulky storage,” “self storage,” and “fine storage.” Bulky storage is assumed to be large product often found on pallets that are in wide aisles. Fine storage is assumed to be small product.

EL1 Savings and Occupant Acceptance (Climate Zones: all)

When using daylight harvesting, skylights, and automatic electric lighting controls to reduce the electric lighting when daylight is present, it is vitally important to commission the control system. A good daylight harvesting system will be invisible to the occupants, but they should be educated on the energy-saving benefits of the system and to spot and report systems that appear to be malfunctioning.

EL2 Reflectance (Climate Zones: all)

Higher surface reflectance on ceilings in the warehouse and self-storage areas will reduce contrast between skylights, luminaires, and ceiling. Reflectance values are available from paint and insulation manufacturers. Reflectance should be verified by the QA provider.

Warehouse and Self Storage. Energy savings outlined in this Guide were based on reflectance of 80-30-20 (ceiling-wall and product-floor). If the reflectance is lower, then additional attention to the ambient lighting energy requirements may be necessary (see DL2). Do not reduce ceiling reflectance.

Office Area. Energy savings outlined in this Guide were based on reflectance of 80-50-20 (ceiling-wall-floor). If the reflectance is lower, then additional attention to the placement of luminaires to the tasks will be necessary to meet the light level recommendations while maintaining the energy requirements. Avoid shiny surfaces (mirrors, polished metals, or stone) in work areas.

EL3 Color Rendering Index (Climate Zones: all)

The color rendering index (CRI) is a scale measurement identifying a lamp's ability to adequately reveal color characteristics of objects and people. The scale maximizes at 100, with 100 indicating the best color-rendering capability. While color rendering may not seem important in warehouse and storage areas, the fluorescent lamps recommended in EL5 for energy-saving properties also have excellent color properties.

EL4 Color Temperature (Climate Zones: all)

Use either 4100 or 5000 K fluorescent lamps. The color temperature is a scale identifying a lamp's relative warmth or coolness—the higher the color temperature, the bluer the source. There are preliminary studies showing that higher color temperature light, in the 5000 K range instead of the 3500 K range, may provide better visual acuity. The higher 4100 K or 5000 K color temperature will also match the daylight from the skylights more closely than the lower (3500 K) color temperature sources.

EL5 Linear Fluorescent Lamps and Ballasts (Climate Zones: all)

To achieve the LPD recommendations in Chapter 3, T-5HO or high-performance T-8 lamps and high-performance electronic ballasts are used for general lighting. The use of standard T-8 and energy-saving T-8 lamps may also be considered for ceiling heights below 10 ft but will result in lower ambient light levels or an increased number of luminaires and lamps to achieve recommended light levels.

High-performance T-8 lamps are defined, for the purpose of this Guide, as having a lamp efficacy of 90+ nominal lumens per watt, based on mean lumens divided by the cataloged lamp input watts. Mean lumens are published in lamp catalogs as the reduced lumen output that occurs at 40% of the lamp's rated life. High-performance T-8s also are defined as having a CRI of 81 or higher and 94% lumen maintenance. The higher performance is achieved by increasing the output (3100 lumens) while keeping the same 32 W input as standard T-8s. Energy-saving T-8 lamps achieve higher performance by reducing the wattage while keeping the light output similar to standard T-8s (e.g., 2750 lumens for 28 W or 2850 lumens for 30 W).

High-performance electronic ballasts are defined, for the purpose of this Guide, as two-lamp ballasts using 55 W or less with a ballast factor (BF) of 0.87 or greater. One-lamp, three-lamp, and four-lamp ballasts may be used but should have the same or better efficiency as the two-lamp ballast. Dimming ballasts do not need to meet this requirement. The high-performance T-8 lamps are visibly brighter than standard T-8s. Using ballasts with a BF of 0.77 may provide more comfortable lamp brightness in office areas and at mounting heights below 10 ft.

- *Program start* ballasts are recommended on frequently switched lamps (switched on and off more than five times a day) because they greatly extend lamp life over frequently switched instant start ballasts. (See EL8.)
- *Instant start* T-8 ballasts typically provide greater energy savings and are the least costly option; also, the parallel operation allows one lamp to operate even if the other burns out. However, instant start ballasts may reduce lamp life, especially when controlled by occupancy sensors or daylight switching systems.
- T-5 ballasts should always be program start.

T-5HO lamps may be a better solution than T-8 lamps in high-ceiling warehouse areas. They have initial lumens per watt that are slightly lower than the high-performance T-8, but they produce approximately twice the lumen output of T-8 lamps, allowing the luminaire to use fewer lamps. In addition to saving energy, T-5HOs use fewer natural resources (glass, metal, phosphors) than a comparable lumen output T-8 system. The T-5HO is also smaller in diameter, allowing the luminaire reflector to be designed to more effectively get light out of the luminaire and down to the floor in high mounting applications.

All fluorescent lamps are temperature sensitive and will produce lower light levels in cold and hot environments. Check with luminaire manufacturers for recommendations on proper luminaire specifications for cold and hot interior environments.

EL6 Compact Fluorescent (Climate Zones: all)

There are industrial luminaires available that use 32 and 42 W compact fluorescent lamps (CFLs). However, these luminaires should be avoided because the typical lamp efficiency is lower and lamp life is normally 50% shorter than that of linear fluorescent lamps.

EL7 Metal Halide (Climate Zones: all)

To achieve the LPD recommendations in Chapter 3, metal halide high-bay and low-bay luminaires may be part of the solution, but they are not recommended for ceiling heights less than 30 ft.

When using metal halide, use pulse-start lamps, which have better lumen maintenance than probe start lamps (approximately 75% for pulse-start and 64% for probe start). Newer electronic HID ballasts also improve lumen maintenance to approximately 86% for the pulse-start lamps and can extend lamp life up to 50%.

Unlike fluorescent lamps, metal halide lamps are not temperature sensitive and may be a better choice in cold or hot interior environments.

Recommendations in Chapter 3 are to occupancy-switch all lights and photocell-switch or dim all lights in the daylight area. Metal halide lamps are not instant-on light sources and can take minutes to restrike, making them difficult to control in response to daylight and occupancy. There are step switching and dimming HID ballasts that can be used for occupancy and daylight harvesting that reduce the lamp power approximately 50%, but normally the lights will not be turned off due to the lamps' restrike time. Without shutting the metal halide light off, energy savings will be reduced. (See DL4 for daylight harvesting savings.)

EL8 Occupancy Sensors (Climate Zones: all)

Use occupancy sensor controls on all luminaires in all areas, including luminaires controlled by daylight dimming/switching systems. In every application it should not be possible for the occupant to override the automatic OFF setting, even if set for manual ON. Unless otherwise recommended, factory-set occupancy sensors should be set for medium to high sensitivity and a 15-minute time delay (the optimum time to achieve energy savings without excessive loss of lamp life). Review manufacturers' data for proper placement, coverage, and Cx requirements.

In office areas, the greatest energy savings are achieved with manual ON/automatic OFF occupancy sensors if daylight is present. This avoids unnecessary operation when electric lights are not needed and greatly reduces the frequency of switching.

For warehouse luminaires, the optimum location for the sensor is integral to or attached to each luminaire. Specify factory-installed sensors to avoid field labor.

For self-storage corridor luminaires, use an integrated occupancy sensor that provides a bi-level, low light level when the space is unoccupied and full light when occupied. In self-storage units, use integrated occupancy sensors or door jamb switches to turn off the light when the unit is not being accessed.

The two primary types of occupancy sensors are *infrared* and *ultrasonic*. Infrared sensors cannot see around corners and caution should be used if using these sensors in storage areas. Ultrasonic sensors can be disrupted by high airflow and should not be used near air duct outlets. Infrared and ultrasonic technologies can be combined into dual-technology occupancy sensors for better coverage and sensitivity.

- If sensors false trigger OFF (turn lights off when someone is present), adjust the time setting up by two minutes on infrared sensors and/or adjust the sensitivity up by 20% on ultrasonic sensors.
- If the lights false trigger ON with ultrasonic sensors, first check for high airflow near the sensors (ultrasonic sensors should not be located near HVAC equipment, including ceiling fans); if the sensor is not in a high airflow area, adjust the sensitivity down by 20%.

EL9 Lighting Circuits and Automatic Controls (Climate Zones: all)

Control luminaires in groups around skylights, and when daylight zones overlap, a single control zone may be used. Areas intended for separate functions (rack areas, shipping, open warehouse areas) should be circuited and controlled separately.

EL10 Electric Lighting Controls in Daylight Zones (Climate Zones: all)

Factory setting of calibrations should be specified when feasible to avoid field labor. Lighting calibration and Cx should be performed after rack installation and after product has been moved into the warehouse to ensure user acceptance. (Refer to DL7 and DL9 for more information.)

EL11 Exit Signs (Climate Zones: all)

Use LED exit signs or other sources that consume no more than 5 W per face. The selected exit sign and source should provide the proper luminance to meet all building and fire code requirements.

EL12 Luminaire Distribution (Climate Zones: all)

In high-ceiling areas with storage racks, use luminaires with an aisle distribution to drive the light to the lower shelves. Use tandem 8 ft long luminaires instead of 4 ft luminaires wherever possible to spread the light up and down the length of the aisle.

EL13 Overhead Glare Control (Climate Zones: all)

Specify luminaires properly shielded for worker comfort by choosing luminaires that include cross louvers to reduce direct view of lamps. Avoid clear-lens, unlouvered luminaires, as the brightness of the lamps will result in glare. Use more or longer luminaires with fewer lamps in cross section to minimize bright points of light against the ceiling. (See EL2 for ceiling reflectance information.)

Sample Design Layouts for Retail Buildings

The 0.6 W/ft² for bulky storage and self storage, 0.85 W/ft² for fine storage, and 0.9 W/ft² for office area recommendations for lighting power (shown in each Recommendation Table in Chapter 3) represent average LPDs for these individual space types, not the entire building. Individual spaces within each space type may have higher power densities if they are offset by lower power densities in other areas within the same space type (corridors in the office areas may be lighted to lower light levels and therefore lower W/ft², allowing higher footcandles and W/ft² in the offices). The example designs described below are one way (but not the only way) that these watts-per-square-foot limits can be met.

EL14 General Lighting in Bulky Storage Areas (Climate Zones: all)

The target lighting in the warehouse area is 10 average maintained *vertical* footcandles. To achieve the 10 average recommended vertical footcandles, design to 15 average maintained horizontal footcandles in the stack areas. Lay out skylights centered in the aisles to meet 5%–7% skylight-to-floor area (see EN19 for recommendations and DL4 for skylight layout recommendations). The typical layout shown in Figure 5-16 uses three-lamp cross section six-lamp high-performance T-8 luminaires spaced equally between the skylights (see DL7 for recommendations of photocell controls).

EL15 General Lighting in Fine Storage Areas (Climate Zones: all)

The target lighting in the warehouse area is 30 average maintained *vertical* footcandles. To achieve the desired light levels, the luminaires in the fine storage are located at 8 ft above the floor. Continue skylight layout from bulky storage to meet 5%–7% skylight-to-floor area (see EN19 for recommendations and DL4 for skylight layout recommendations). The typical layout shown in Figure 5-17 uses 1-lamp cross section high-performance T-8 luminaires centered in the aisle (see DL7 for recommendations of photocell controls).

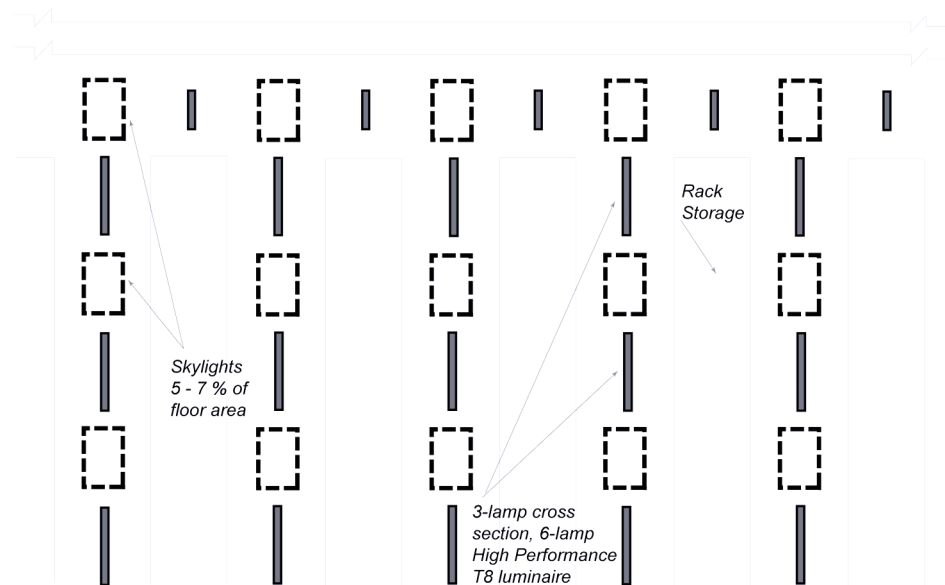

Figure 5-16. (EL14) Layout for bulky storage.

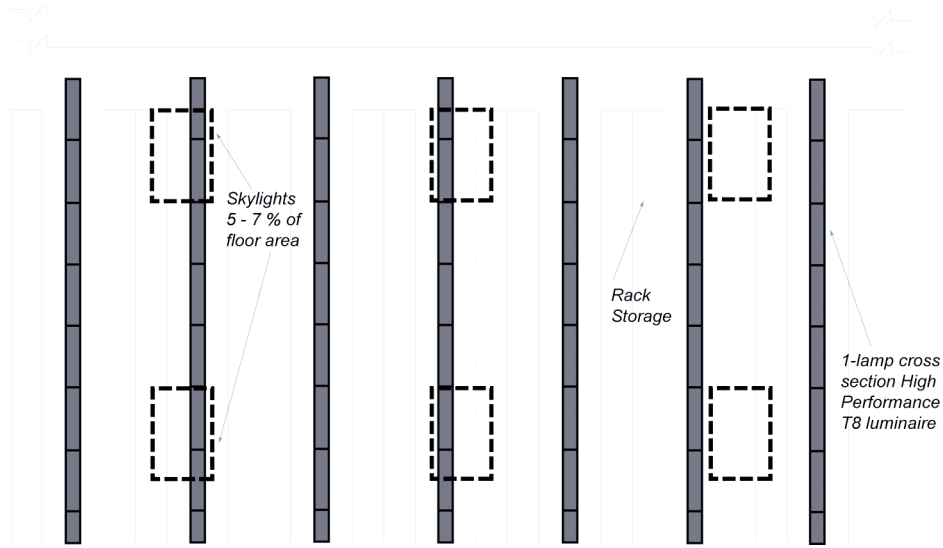

Figure 5-17. (EL15) Layout for fine storage.

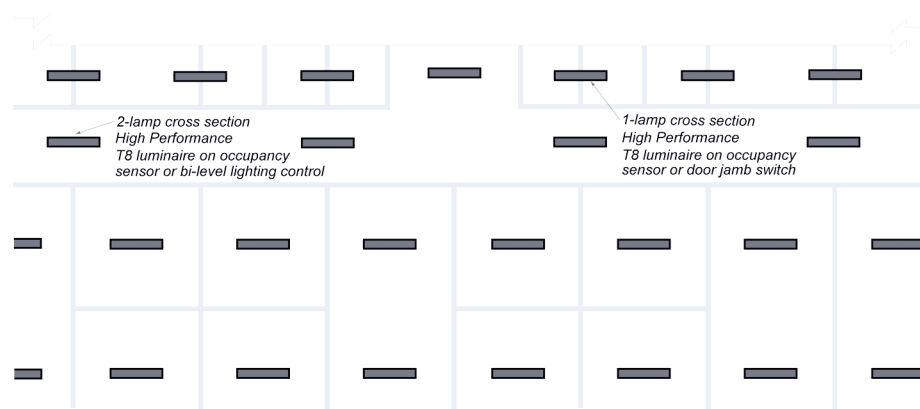
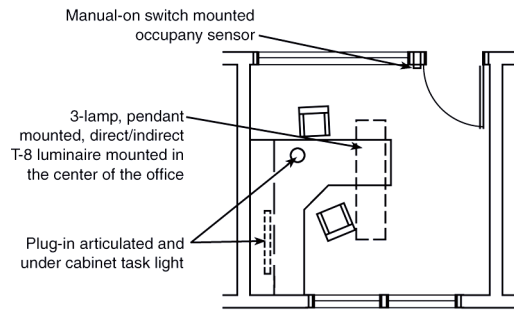

Figure 5-18. (EL16) Layout for self storage.

EL16 *General Lighting in Self-Storage Areas (Climate Zones: all)*

The target lighting in the self-storage area is 10 average maintained horizontal foot-candles. To achieve the desired light levels, the luminaires in the self-storage area are located at 10 ft above the floor. The typical layout shown in Figure 5-18 uses 2-lamp cross section high-performance T-8 luminaires centered in the aisle; these luminaires use integrated occupancy sensors (leave lights at entries on or use luminaires with bi-level lighting control). Use 1-lamp cross section high-performance T-8 luminaires over each self-storage unit with an occupancy or door jamb switch).

EL17 General Lighting in Office Areas (Climate Zones: all)**Figure 5-19.** (EL17) Layout for office.

The target lighting in private offices is 30 average maintained footcandles for ambient lighting with a total of at least 50 footcandles provided on the desktop by a combination of the ambient and supplemental task lighting. Office areas account for approximately 5% of the floor area and should be limited to 0.90 W/ft², including circulation. The layout shown in Figure 5-19 is about 1.0 W/ft².

EL18 General Lighting in Other Spaces (Climate Zones: all)

Lighting in other spaces including restrooms, electrical/mechanical rooms, break rooms, workshops, and others should be limited to 0.9 W/ft², which is equivalent to about one two-lamp high-performance T-8 luminaire every 64 ft². Use occupancy sensors or timers where appropriate.

References

- ASHRAE. 2004. *Advanced Energy Design Guide for Small Office Buildings*. Atlanta: American Society of Heating, Refrigerating and Air-Conditioning Engineers, Inc.
- DLC. 2008. *Warehouse Skylighting knowhow™ Design Guide*. DesignLights™ Consortium. www.designlights.org/guides.html.
- IESNA. 1997. *EPRI Lighting Controls: Smart and Simple*. New York: Illuminating Engineering Society of North America.
- IESNA. 2001. *ANSI/IESNA RP-7-01, Recommended Practice on Lighting Industrial Areas*. New York: Illuminating Engineering Society of North America.
- USGBC. 2005. LEED NC Indoor Environment Quality Credit 6.1, "Controllability of Systems: Lighting." Washington, DC: U.S. Green Building Council.

*Exterior Electric Lighting***Good Design Practice**

Exterior lighting should be turned off or reduced by at least 50% one hour after normal business hours in response to light pollution and light trespass concerns. Maintain lighting that is required for safety and security.

EL19 Under Canopy Lighting (Climate Zones: all)

Limit exterior lighting to 0.5 W/ft² of the area under the canopy. This does not include lighting of walkways or entry areas (see EX1 recommendations for these areas).

EL20 Sources (Climate Zones: all)

All general lighting luminaires should utilize pulse-start metal halide, ceramic metal halide, fluorescent, or CFL amalgam lamps with electronic ballasts.

Standard high-pressure sodium lamps are not recommended due to their reduced visibility and poor color-rendering characteristics. Incandescent lamps are also not recommended.

For colder climates, fluorescent and CFL luminaires must be specified with cold-temperature ballasts. Use CFL amalgam lamps.

EL21 Controls (Climate Zones: all)

Use an astronomical time switch or a combination of a photosensor and a time switch for all exterior lighting. Time switches are capable of retaining programming and time settings during loss of power for a period of at least seven days. If a building energy management system is being used to control and monitor mechanical and electrical energy use, it can also be used to schedule and manage outdoor lighting energy use. Turn off exterior lighting not designated for security purposes when the building is unoccupied.

Recommendations for parking lots and grounds are included in “Bonus Savings” sections EX1 through EX4 at the end of this chapter.

References

- IESNA. 1994. *IESNA DG-5-94, Recommended Lighting for Walkways and Class 1 Bikeways. Recommended Practices and Design Guidelines*. New York: Illuminating Engineering Society of North America.
- IESNA. 1998. *IESNA RP-20-1998, Lighting for Parking Facilities. Recommended Practices and Design Guidelines*. New York: Illuminating Engineering Society of North America.
- IESNA. 1999. *IESNA RP-33-99, Lighting for Exterior Environments. Recommended Practices and Design Guidelines*. New York: Illuminating Engineering Society of North America.
- IESNA. 2003. *IESNA G-1-03, Guideline on Security Lighting for People, Property and Public Spaces. Recommended Practices and Design Guidelines*. New York: Illuminating Engineering Society of North America.
- RPI. 1996. *Outdoor Lighting Pattern Book*. Troy, NY: Rensselaer Polytechnic Institute.
- USGBC. 2005. LEED NC Sustainable Sites Credit 8, “Light Pollution Reduction.” Washington, DC: U.S. Green Building Council.

HVAC

Good Design Practice

HV1 General (Climate Zones: all)

The HVAC equipment for this Guide includes packaged-unit systems and split systems generally referred to as *air-conditioning* or *heat pump* units (see Figure 5-20) and certain heating-only systems, such as radiant heaters and unitary air heating devices (see Figure 5-21). These systems are suitable for projects with no central plant. This Guide does not cover water-source or ground-source heat pumps; systems that use liquid water chillers or purchased chilled water for cooling; or oil, hot water, solar, steam, or purchased steam for heating. These systems are alternative means that may be used to achieve the energy savings target of this Guide.

The systems and equipment included in this Guide are available in pre-established increments of capacity with a refrigeration cycle and/or a heating source. The components are factory designed and assembled and can include fans, motors, filters, heating source, cooling coil, refrigerant compressor, controls, and condenser. The components can be in a single package or a split system that separates the evaporator and condenser sections.

Performance characteristics vary among manufacturers, and the selected equipment should match the calculated heating and cooling loads (sensible and latent), also taking into account the importance of meeting latent cooling loads under part-load conditions. (See HV3 for calculating the loads, HV4 for meeting latent cooling loads under part-load conditions, HV9 to ensure that the appropriate amount of ventilation air is provided, and HV13 for recommendations on zoning the building. See HV21 for a discussion on the location of space thermostats.) The equipment should be listed as being in conformance with electrical and safety standards with its performance ratings certified by a nationally recognized certification program.

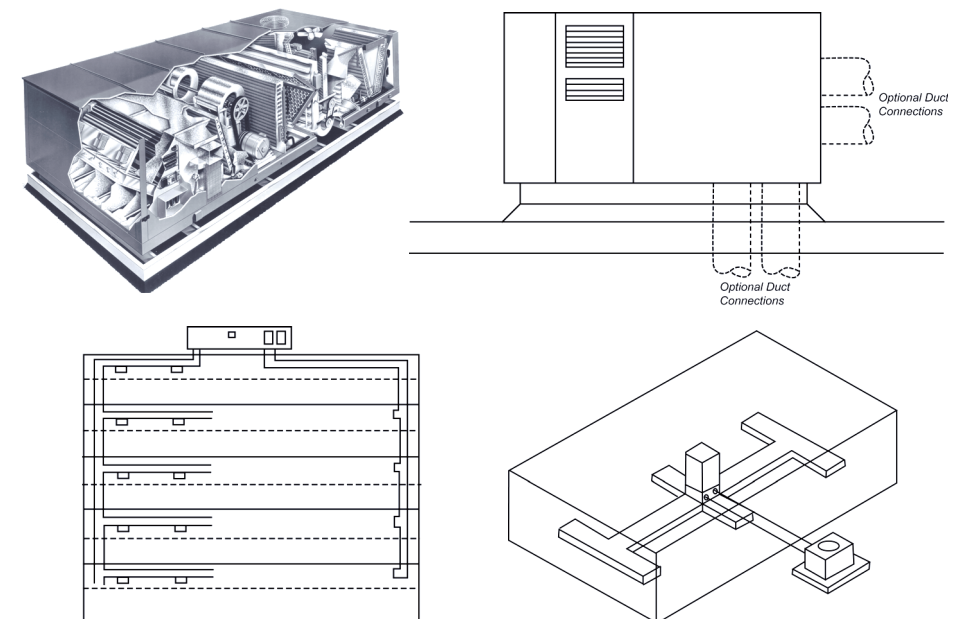

Figure 5-20. (HV1) Typical HVAC packaged unit and split system layouts.

Single packaged units can be mounted on the roof, at grade level, or indoors. Split systems generally have the blower unit, including filters and coils, located indoors or in unconditioned space and the condensing unit outdoors on the roof or at grade level. On smaller systems, the blower is commonly incorporated in an indoor furnace section. The blower unit may also be located outdoors; if so, it should be mounted on the roof to avoid ductwork outside the building envelope. (See HV9 for further discussion on the ductwork recommendations.) The equipment should be located in a position that results in minimizing fan power, ducting, and wiring.

HV2 HVAC System Types (Climate Zones: all)

This Guide considers packaged unit systems and split systems with a refrigerant-based direct expansion system for electric cooling and heating by means of one of the four following options:

- Option 1: Gas-fired air heaters (including gas-fired unit heaters and outside air units)
- Option 2: Electric resistance heat
- Option 3: Heat pump unit
- Option 4: Radiant heater

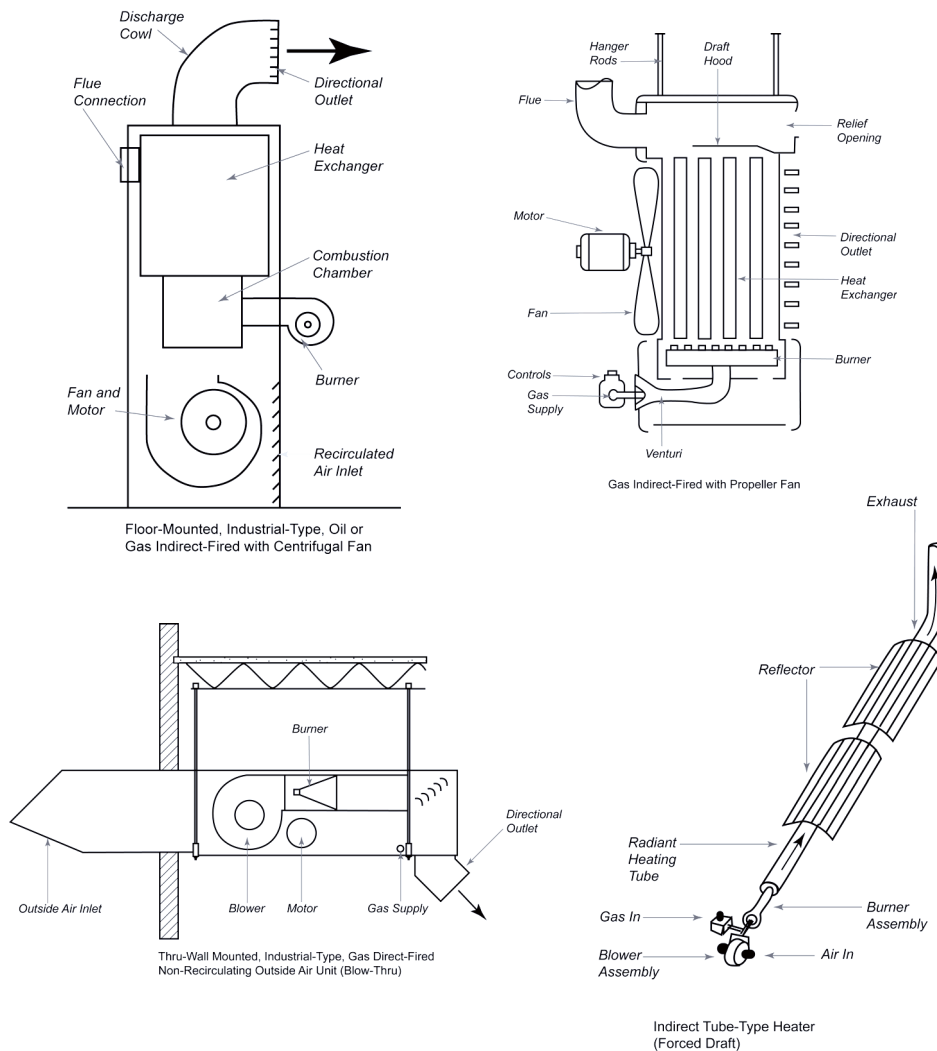

Figure 5-21. (HV1) Typical HVAC heating equipment (unit and outside air heaters and radiant heaters). *Bottom left image adapted from a drawing provided by Cambridge Engineering, Inc.*

Gas-fired air heaters may be direct or indirect. Direct gas-fired air heaters do not require a flue but convey products of combustion into the conditioned space and may require reconsideration of outside air ventilation requirements to dilute these products. Indirect-fired air heaters use a heat exchanger as part of the factory-assembled unit to separate the burner and products of combustion from the circulated air and require a flue.

Unit heaters, often used in storage spaces, typically have no ductwork and induce air locally while projecting the air a short distance through their discharge velocity.

Outside air units utilize 100% outside air and may be direct or indirect. When outside air units are utilized as the primary heat source for a conditioned space, ventilation flow requirements and heating airflow requirements should be reconciled to avoid excessive introduction of outside air. Ventilation requirements and heating flow requirements can be balanced by using a higher heating air supply temperature along with appropriate air distribution strategies to avoid stratification.

Electric resistance heaters can be part of the factory-assembled unit or can be installed in the duct distribution system.

The auxiliary heat source for heat pump units may also be used to supply heating to the space during the defrost cycle and can be either electric or gas.

Radiant heaters heat the surfaces at which they are directed through infrared radiation. They are very effective in high bay and high air exchange spaces because they warm surfaces directly rather than heating the air. They are usually supplemented by air systems.

Where variable-air-volume (VAV) systems are used, the refrigeration system requires reduced capacity in response to reduced load. The package unit should be designed to maintain the required apparatus dew point for humidity control. The minimum flow setpoint of variable-volume systems should be set at the required minimum outside air ventilation flow, and supply air temperature should be reset upward during low cooling load periods to avoid reheating. Reheating should only be used when dehumidification is required during low sensible cooling load periods. Variable-speed drives should be considered as an option to reduce airflow and fan/motor energy. Packaged direct expansion VAV units with variable-speed compressors provide especially high efficiency operation at part load.

HV3 Cooling and Heating Loads (Climate Zones: all)

Cooling and heating system design loads should be calculated in accordance with generally accepted engineering standards and handbooks, such as *ASHRAE Handbook—Fundamentals* or *ACCA Manual N*. Any safety factor should be applied cautiously and only to a building's internal loads to prevent oversizing of equipment. If the unit is oversized and the cooling capacity reduction is limited, short-cycling of compressors could occur and the system may not have the ability to dehumidify the building properly. Include the cooling and heating loads of the outdoor air to determine the total cooling and heating requirements of the unit. In determining cooling requirements, the sensible and latent loads to cool the outdoor air to the maximum allowable space temperature must be added to the building cooling load. For heating, the outdoor air brought into the space must be heated to the minimum allowable space temperature, and the heat required must be added to the building heat loss. On VAV systems, the minimum supply airflow to a zone should comply with local code, the current ASHRAE Standard 62.1, and the current ASHRAE/IESNA Standard 90.1 and should be taken into account in calculating heating loads of the outdoor air.

HV4 Temperature and Humidity Control (Climate Zones: all)

The sensible cooling load in a building is not necessarily proportional to the latent load, and in humid climates high relative humidity levels can occur during low sensible load periods. Select systems maintain low apparatus dew point during part-load operation and provide humidity control during low sensible load periods. Variable-volume air delivery and multiple-capacity or variable-speed compressors not only maintain

humidity control but also provide enhanced energy efficiency during part-load operation. These systems also avoid the cycling losses that are inherent to non-unloading systems that must continuously turn on and off to avoid overcooling. Storage spaces, in particular, may have periods of time that require some dehumidification with little or no sensible cooling load. Packaged or split systems with inverter-driven compressors and variable-speed fans can operate with very high efficiency at low part load to maintain humidity levels without overcooling the space, cycling excessively, or employing energy-inefficient hot-gas bypass.

In moderate heating climates, storage occupancies sustain many hours of part-load heating requirements due to low internal loads and relatively high envelope thermal resistance. These loads occur at relatively high outdoor temperatures, at which electric heat pumps operate efficiently. Variable-volume airflow and variable compressor capacity provide enhanced part-load performance during heating operation of heat pump systems just as they enhance efficiency during cooling operation.

HV5 Radiant Heating (Climate Zones 5 6 7 8)

Some components of storage occupancies, such as loading docks, are quite challenging for temperature maintenance and freeze prevention due to high air infiltration rates. Radiant heating can be successful in maintaining higher surface temperatures even while air temperatures drop because of outside air exchange. Radiant systems are also effective in maintaining higher floor temperatures and reducing thermal stratification than are all simple all-air systems. Higher floor and interior surface temperatures result in higher maintained internal mass temperatures, facilitating air temperature recovery after temporary high-infiltration events, such as opening dock doors. Radiant systems must be supplemented by air systems for maintenance of appropriate ventilation rates, for pressure balance between the building and outside, and of overall desired air temperature. Detailed considerations and techniques for sizing and implementing radiant heating systems, along with additional references, can be found in *ASHRAE Handbook—HVAC Systems and Equipment*, Chapter 15.

HV6 Energy Recovery (Climate Zones: all)

Total energy recovery equipment can provide an energy-efficient means of dealing with the latent and sensible outdoor air cooling loads during peak summer conditions. It can also reduce the required heating of outdoor air in cold climates.

Exhaust air energy recovery can be provided through a separate energy recovery ventilator (ERV) that conditions the outdoor air before entering the air-conditioning or heat pump unit, an ERV that attaches to an air-conditioning or heat pump unit, or an air-conditioning or heat pump unit with the ERV built into it.

For maximum benefit, energy recovery designs should provide as close to balanced outdoor and exhaust airflows as is practical, taking into account the need for building pressurization and any exhaust that cannot be incorporated into the system. Exhaust for ERVs may be taken from spaces requiring exhaust (using a central exhaust duct system for each unit) or directly from the return airstream (as with a unitary accessory or integrated unit).

Where economizers are used with an ERV, the energy recovery system should be controlled in conjunction with the economizer and provide for the economizer function. Where energy recovery is used without an economizer, the energy recovery system should be controlled to prevent unwanted heat, and an outdoor air bypass of the energy recovery equipment should be used. In cold climates, manufacturers' recommendations for frost control should be followed.

In cold climates, storage spaces requiring high ventilation rates typically have minimal internal loads to offset heat loss from the required ventilation. Heat recovery can reduce the heat loss significantly, tempering energy requirements for outside air, but increased pressure drop through heat exchangers will result in higher fan energy

consumption. Analysis is required to determine whether reduced thermal energy consumption for outside air tempering offsets increased fan energy consumption.

HV7 Destratification (Climate Zones: 5 6 7 8)

Air heating systems for high bay spaces in cold climates often cause excessive temperatures near the ceiling in order to achieve desired air temperatures near the floor, resulting in excessive roof heat losses, increased heating loads, and excessive energy usage. Unit heaters in high bay spaces often result in significant stratification. Destratifying fans and ducts or higher-velocity vertical-throw diffusers can increase air exchange between the upper and lower zones of the space, reducing the range of temperatures over the height of the space. Air rotation technologies similarly provide a reduction in stratification for space heating. During overheated periods, however, destratification can result in elevated air temperatures near the floor because thermal heat gains that occur higher in the space are mixed into the air in the occupied zone. Automatic or manual disabling of destratification systems is recommended during overheated periods.

HV8 Equipment Efficiency (Climate Zones: all)

The cooling equipment should meet or exceed the listed seasonal energy efficiency ratio (SEER) or energy efficiency ratio (EER) for the required capacity. The cooling equipment should also meet or exceed the integrated part-load value (IPLV) where shown.

Heating equipment should meet or exceed the listed annual fuel utilization efficiency (AFUE) or thermal efficiency for gas-fired air heaters at the required capacity. For heat pump applications, the heating efficiency should meet or exceed the listed heating seasonal performance factor (HSPF) or coefficient of performance (COP) for the required capacity based on 47°F outdoor air temperature.

HV9 Ventilation Air (Climate Zones: all)

The amount of outdoor air should be based on ASHRAE Standard 62.1 but in no case be less than the values required by local code. The number of people used in computing the ventilation quantity required should be based on either known occupancy, local code, or ASHRAE Standard 62.1. For storage occupancies, ventilation rates may be based on pollutant sources, off-gassing or dust production of the handled materials, or usable floor area. Determination of ventilation rates should recognize all possible pollutant sources in the space, including carbon monoxide from fork lift motors and off-gassing of materials. Ventilation guidelines for different pollutants are detailed in the standard.

Each air-conditioning or heat pump system should have an outdoor air connection through which ventilation air is introduced and mixes with the return air. The outdoor air can be mixed with the return air either in the ductwork prior to the air-conditioning or heat pump unit or at the unit's mixing plenum. In either case, the damper and duct/plenum should be arranged to promote mixing and minimize stratification (see Figure 5-22).

An air economizer mode can save energy by using outdoor air for cooling in lieu of mechanical cooling when the temperature of the outdoor air is low enough to meet the cooling needs. The system should be capable of modulating the outdoor air, return air, and relief air dampers to provide up to 100% of the design supply air quantity as outdoor air for cooling.

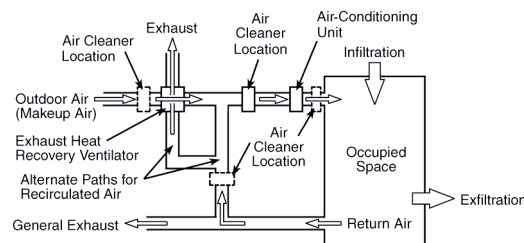

Figure 5-22. (HV9) Example of ventilation system.

Systems should use a motorized low-leakage outdoor air damper instead of a gravity damper to prevent outdoor air from entering during the unoccupied periods when the unit may recirculate air to maintain setback or setup temperatures. The motorized outdoor air damper for all climate zones should be closed during the entire unoccupied period except when it may open in conjunction with an economizer cycle. Nonessential exhaust systems should be interlocked with the building main HVAC systems to be disabled when systems are not operating.

HV10 Exhaust Air (Climate Zones: all)

Central exhaust systems for restrooms, janitorial closets, etc., within conditioned space, should be interlocked to operate with the air-conditioning or heat pump unit except during unoccupied periods. These exhaust systems should have a motorized damper that opens and closes with the operation of the fan. The damper should be located as close as possible to the duct penetration of the building envelope to minimize conductive heat transfer through the duct wall and avoid having to insulate the duct. During unoccupied periods, the damper should remain closed and the exhaust fan turned off, even while the air-conditioning or heat pump unit is operating, to maintain setback or setup temperatures.

For bulk storage spaces, exhaust fans used to increase outside airflow to minimize interior temperatures during summer months should be equipped with low-leakage automatic louver dampers to reduce infiltration during heating periods. Intake air hoods or louvers for the exhaust system should be equipped with barometric dampers to minimize infiltration when exhaust fans are not in operation. Dampers should begin to open at no more than 0.04 in. w.c. pressure and should be fully open at 0.10 in. of pressure.

HV11 Ductwork Distribution (Climate Zones: all)

Ductwork is not usually used in heated-only storage occupancies. Radiant heaters, unit heaters, and some outside air units do not have ductwork. Ventilation air is often exchanged centrally. The offices associated with storage occupancies use rooftop, split, and unitary air-conditioning systems. Office air-conditioning systems should use sufficient ductwork to achieve proper airflow and ventilation.

Air should be ducted through low-pressure ductwork with a system pressure classification of less than 2 in. Where practical, rigid ductwork is preferred. Supply air should be ducted to supply diffusers in each individual space. Return air should be ducted from return registers provided in appropriate locations for proper airflow, but not necessarily in every space. The ductwork should be as direct as possible, minimizing the number of elbows, abrupt contractions and expansions, and transitions. Long-radius elbows and 45° lateral take-offs should be used wherever possible. Where VAV systems are used, they should have single-duct air terminal units to control the volume of air to the zone based on the space temperature sensor.

In general, the following sizing criteria should be used for the duct system components:

- a. Diffusers and registers should be sized with a static pressure drop no greater than 0.08 in.
- b. Supply and return ductwork should be sized with a pressure drop no greater than 0.08 in. per 100 linear ft of duct run.
- c. Flexible ductwork should be of the insulated type and should be
 1. limited to connections between duct branch and diffusers,
 2. limited to connections between duct branch and VAV terminal units,
 3. limited to 5 ft (fully stretched length) or less,
 4. installed without any kinks,
 5. installed with a durable elbow support when used as an elbow, and
 6. installed with no more than 15% compression from fully stretched length, and

7. hanging straps, if used, need to use a saddle to avoid crimping the inside cross-sectional area. For ducts with 12 in. or less diameter, use a 3 in. saddle; for larger than 12 in., use a 5 in. saddle.

Ductwork should not be installed outside the building envelope in order to minimize heat gain to or heat loss from the ductwork due to outdoor air temperatures and solar heat gain. Ductwork on rooftop units should enter or leave the air-conditioning or heat pump unit through an insulated roof curb around the perimeter of the air-conditioning or heat pump unit's footprint.

Duct board should be airtight (duct seal level B, from ASHRAE/IESNA Standard 90.1) and should be taped and sealed with products that maintain adhesion. Duct static pressures should be designed and equipment and diffuser selections should be selected to not exceed the noise criteria for the space. (See HV21 for additional information.)

HV12 Duct Insulation (Climate Zones: all)

All supply air ductwork should be insulated. All return air ductwork located above the ceiling and below the roof should be insulated. Any outdoor air ductwork should be insulated. All exhaust and relief air ductwork between the motor-operated damper and penetration of the building exterior should be insulated.

Include a vapor barrier on the outside of the insulation where condensation is possible. The vapor barrier should be sealed to prevent air intrusion and resulting condensation in the insulation.

Exception: In conditioned spaces without a finished ceiling, only the supply air duct mains and major branches should be insulated. Individual branches and run-outs to diffusers in the space being served do not need to be insulated, except where it may be necessary to prevent condensation.

HV13 Duct Sealing and Leakage (Climate Zones: all)

The ductwork should be sealed for duct seal level B from ASHRAE/IESNA Standard 90.1 and leak-tested at the rated pressure. The leakage should not exceed the allowable cfm/100 ft² of duct area for the seal and leakage class of the system's air quantity apportioned to each section tested. (See HV17 for guidance on ensuring the air system performance.)

HV14 Fan Motors (Climate Zones: all)

Motors for fans 1 hp or greater should meet National Electrical Manufacturers Association (NEMA) premium efficiency motor guidelines when available (see www.nema.org).

HV15 Thermal Zones (Climate Zones: all)

Office spaces for warehouses should be divided into thermal zones based on building size, part-load performance requirements, space layout and function, number of occupants, and the needs of the user. In a warehouse building with similar internal loads throughout, a minimum of one zone for the interior and one for the loading area is recommended. Heated-only storage occupancies often are zoned according to the location of heating devices. Separate devices in loading dock areas often result in beneficial separate zoning for that area. Fully conditioned warehouses are often single zone because of the uniformity of loading within the space and because close temperature control is usually not required. The office area should be zoned for perimeter spaces and interior rooms (see Figure 5-23).

(HV15 continues on next page)

Zoning can also be accomplished using multiple air-handling units or by having multiple zone control with a single air-handling unit. The temperature sensor for a zone should be installed in a location representative of that entire zone.

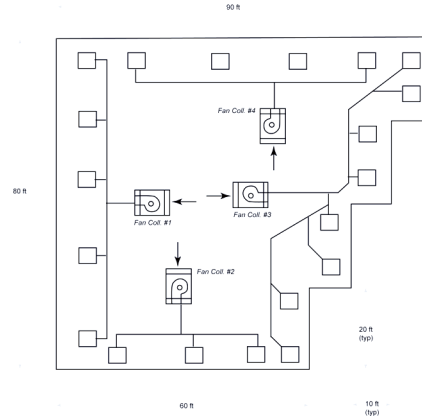

Figure 5-23. (HV15) Perimeter system zoning.

HV16 *Control Strategies (Climate Zones: all)*

Control strategies can be designed to help reduce energy. Time-of-day scheduling is useful when it is known which portions of the building will have reduced occupancy. Control of the ventilation air system can be tied into this control strategy.

Having a setback temperature for unoccupied periods during the heating season or setup temperature during the cooling season will help to save energy. A pre-occupancy operation period will help to purge the building of contaminants that build up overnight from the outgassing of products and packaging materials. In hot, humid climates, care should be taken to avoid excessive relative humidity conditions during unoccupied periods.

HV17 *Testing, Adjusting, and Balancing (TAB) (Climate Zones: all)*

After the system has been installed, cleaned, and placed in operation, the system should be tested, adjusted, and balanced for proper operation. This procedure will help to ensure that the correctly sized diffusers, registers, and grilles have been installed, that each space receives the required airflow, that the equipment meets the intended performance, and that the controls operate as intended. The TAB subcontractor should certify that the instruments used in the measurement have been calibrated within 12 months prior to use. A written report should be submitted for inclusion in the O&M manuals.

HV18 *Filters (Climate Zones: all)*

Air-conditioning and heat pump unit filters are included as part of the factory-assembled unit and should be at least *MERV 8*, based on *ASHRAE Standard 52.2*. On constant-volume systems, use a filter differential pressure gauge to monitor the pressure drop across the filters. The gauge should be checked and the filter should be inspected on a routine basis. Filters should be replaced when their pressure drop exceeds the filter manufacturer's recommendations for replacement or when visual inspection indicates the need. A monitor should be included to send an alarm if the predetermined pressure drop is exceeded. Upon completion of construction, all filters should be replaced prior to building occupancy.

Cautions

HV19 Heating Sources (Climate Zones: all)

Forced-air electric resistance and gas-fired heaters require a minimum airflow rate to operate safely. These systems, whether stand-alone or incorporated into an air-conditioning or heat pump unit, should include factory-installed controls to shut down the heater when there is inadequate airflow resulting in high air temperatures.

HV20 Return and Relief Air (Climate Zones: all)

Relief (rather than return) fans or blowers should be used when necessary to maintain building pressurization during economizer operation. However, where return duct static pressure exceeds 0.5 in. of water, return fans should be used.

HV21 Noise Control (Climate Zones: all)

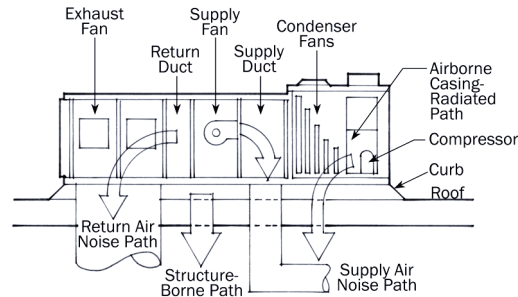

Figure 5-24. (HV21) Typical noise paths for roof-top-mounted HVAC units.

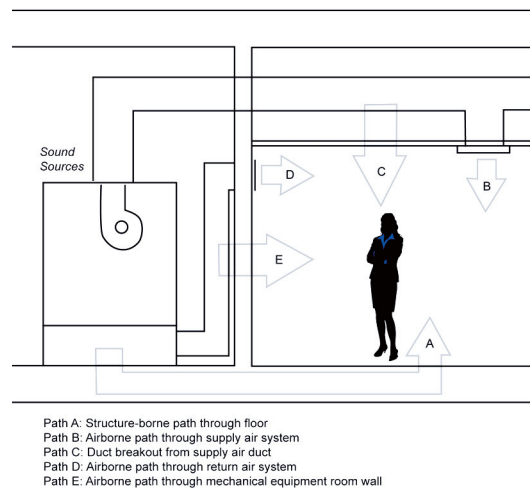

Figure 5-25. (HV19) Typical noise paths for interior-mounted HVAC units.

HV22 Heating Supply Air Temperatures (Climate Zones: all)

Stratification can be a significant problem when heating high bay spaces. Duct configurations and supply air registers should be selected based on discharge air temperature and flow rate to avoid excess stratification. Heating supply temperatures in high bay storage spaces should be maintained as low as possible to meet the heating load, and appropriate air diffusion strategies should be utilized to project the warm heating air down to the occupied zone near the floor of the space. (See HV7.)

Acoustical requirements may necessitate attenuation of the noise associated with the supply and/or return air, but the impact on fan energy consumption should also be considered and, if possible, compensated for in other duct or fan components. Acoustical concerns may be particularly critical in short, direct runs of ductwork between the fan and supply or return outlet. Where practical, avoid installation of the air-conditioning or heat pump units above office and break areas. Consider locations above less critical spaces such as storage areas, restrooms, corridors, etc. (See Figures 5-24 and 5-25 for typical noise paths for HVAC units.)

HV23 Zone Temperature Control (Climate Zones: all)

The number of spaces in a zone and the location of the temperature-sensing point will affect the control of temperature in the various spaces of a zone. Locating the thermostat in one room of a zone with multiple spaces provides feedback based only on the conditions of that room. Locating a single thermostat in a large open area may provide a better response to the conditions of the zone with multiple spaces. Selecting the room or space that will best represent the thermal characteristics of the space due to both external and internal loads will provide the greatest comfort level.

To prevent misreading of the space temperature, zone thermostats should not be mounted on an exterior wall or directly in the path of air diffusion from supply outlets. Where this is unavoidable, use an insulated sub-base for the thermostat.

Zoning and temperature control in storage spaces, especially near often open loading doors, should be based on the intent or need for temperature control: occupant comfort, product protection, or freeze protection. Air temperatures close to open loading doors will often be very near outside ambient. Radiant heating or local air heaters may be effective in cold climates for such locations.

HV24 Economizers (Climate Zones: 3 4 5 6 7 8)

Economizers, when recommended, should be employed on air conditioners to help save energy by providing free cooling when ambient conditions are suitable to meet all or part of the space cooling load. Consider using enthalpy controls (versus dry-bulb temperature controls) to help ensure that unwanted moisture is not introduced into the space in hot, humid climates. Economizers are not recommended in climate zone 1. There may be some applicability in dry climate areas in climate zone 2. Periodic maintenance is important with economizers, as dysfunctional economizers can cause substantial excess energy consumption due to malfunctioning dampers and/or sensors.

Systems that control outside air volume to maintain a positive pressure setpoint in the space can supply excessive amounts of outside air, entailing significant additional energy consumption, when open loading docks permit increased exfiltration from the building. For systems with 100% outside air capability, provision of outside air during disadvantageous weather conditions should be limited to the minimum volume required for maintaining indoor air quality.

References

- ACCA. 2008. *Manual N—Commercial Load Calculation*, 5th ed. Arlington, VA: Air Conditioning Contractors of America.
- ASHRAE. 2004. *ASHRAE Handbook—HVAC Systems and Equipment*. Atlanta: American Society of Heating, Refrigerating and Air-Conditioning Engineers, Inc.
- ASHRAE. 2007. *ASHRAE Standard 62.1-2007, Ventilation for Acceptable Indoor Air Quality*. Atlanta: American Society of Heating, Refrigerating and Air-Conditioning Engineers, Inc.
- ASHRAE. 2005. *ASHRAE Handbook—Fundamentals*. Atlanta: American Society of Heating, Refrigerating and Air-Conditioning Engineers, Inc.
- ASHRAE. 2007. *ANSI/ASHRAE Standard 52.2-2007, Method of Testing General Ventilation Air-Cleaning Devices for Removal Efficiency by Particle Size*. Atlanta: American Society of Heating, Refrigerating and Air-Conditioning Engineers, Inc.
- ASHRAE. 2007. *ANSI/ASHRAE/IESNA Standard 90.1, Energy Standard for Buildings Except Low-Rise Residential Buildings*. Atlanta: American Society of Heating, Refrigerating and Air-Conditioning Engineers, Inc.
- ASHRAE. 2007. *ASHRAE Handbook—HVAC Applications*. Atlanta: American Society of Heating, Refrigerating and Air-Conditioning Engineers, Inc.
- National Electrical Manufacturers Association, www.nema.org, Standards and Publications section.

SERVICE WATER HEATING

Good Design Practice

WH1 Service Water Heating Types (Climate Zones: all)

The service water heating (SWH) equipment discussed in this Guide is considered to use the same type of fuel source used for the HVAC heating system. This Guide does not cover systems that use oil, hot water, steam, or purchased steam for generating SWH. The Guide also does not address the use of solar or site-recovered energy (including heat pump water heaters). These systems are alternative means that may be used to achieve 30% or greater savings over ASHRAE/IESNA Standard 90.1-1999 and, where used, the basic principles of this Guide would apply.

The SWH equipment included in this Guide for the HVAC options listed in HV2 are the gas-fired water heater and the electric water heater.

Both natural gas and propane fuel sources are available options for gas-fired units.

WH2 System Description (Climate Zones: all)

1. **Gas-fired storage water heater.** A water heater with a vertical or horizontal water storage tank. A thermostat controls the delivery of gas to the heater's burner. The heater requires a vent to exhaust the products of combustion.
2. **Gas-fired instantaneous water heater.** A water heater with minimal water storage capacity. The heater requires a vent to exhaust the products of combustion. An electronic ignition is recommended to avoid the energy losses from a standing pilot.
3. **Electric resistance storage water heater.** Water heater consisting of a vertical or horizontal storage tank with one or more immersion heating elements. Thermostats controlling heating elements may be of the immersion or surface-mounted type. For typical warehouse office applications, small water heaters are available from 2–20 gal.
4. **Electric resistance instantaneous water heater.** Compact, under-cabinet, or wall-mounted types with insulated enclosure and minimal water storage capacity; a thermostat controls the heating element, which may be of the immersion or surface-mounted type. Instantaneous, point-of-use water heaters should provide water at a constant temperature regardless of input water temperature.

WH3 Sizing (Climate Zones: all)

The water heating system should be sized to meet the anticipated peak hot-water load, typically about 0.4 gal per hour per employee in the average warehouse building. The hot water demand will be higher if showers or other high-volume uses exist, and these should be accounted for in sizing equipment. The supply-water temperature should be no higher than 120°F to avoid injuries due to scalding.

WH4 Equipment Efficiency (Climate Zones: all)

Efficiency levels are provided in the Guide for gas-fired instantaneous, gas-fired storage, and electric resistance storage water heaters. For gas-fired instantaneous water heaters, the energy factor and thermal efficiency levels correspond to commonly available instantaneous water heaters.

The gas-fired storage water heater efficiency levels correspond to condensing storage water heaters. High-efficiency, condensing gas storage water heaters (energy factor > 0.90 or thermal efficiency > 0.90) are alternatives to the use of gas-fired instantaneous water heaters.

Electric storage water heater efficiency should be calculated as $0.99 - 0.0012 \times$ water heater volume. Instantaneous electric water heaters are an acceptable alternative

to high-efficiency storage water heaters. Electric instantaneous water heaters are more efficient than electric storage water heaters, and point-of-use versions will minimize piping losses. However, their impact on building peak electric demand can be significant and should be taken into account during design.

WH5 *Location (Climate Zones: all)*

The water heater should be located close to the hot-water fixtures to avoid the use of a hot-water return loop or the use of heat tracing on the hot-water supply piping. Where electric resistance heaters are used, point-of-use water heaters should be considered when there is a low number of fixtures or where they can eliminate the need for a recirculating loop.

WH6 *Pipe Insulation (Climate Zones: all)*

All SWH piping should be installed in accordance with accepted industry standards. Insulation levels should be in accordance with the recommendation levels in Chapter 3, and the insulation should be protected from damage. Include a vapor retardant on the outside of the insulation.

Reference

ASHRAE. 2007. *ASHRAE Handbook—HVAC Applications*. Atlanta: American Society of Heating, Refrigerating and Air-Conditioning Engineers, Inc.

BONUS SAVINGS

Ventilation Control

VC1 *Demand-Control Ventilation*

Demand-control ventilation should be used only in areas that have varying and high occupancy loads during the occupied periods to vary the amount of outdoor air in response to the need in a zone. In warehouse or other areas in which the occupant population is not the most important determinant of ventilation flow rate, demand-control ventilation using carbon dioxide sensors should not be used. The amount of outdoor air can be controlled by comparing concentration readings of CO₂ sensors in the outside air and in the space, as a proxy for the adequacy of ventilation based on occupancy, for office and retail merchandise areas. A controller will operate the outdoor air, return air, and relief air dampers to maintain proper ventilation according to the occupancy level. Minimum outside air damper position for conditioned spaces should be based on minimum required space pressurization or on ASHRAE Standard 62.1 requirements for unoccupied space, whichever is greater.

The number and location of CO₂ sensors for demand-control ventilation can affect the ability to accurately reflect the building or zone occupancy. A minimum of one CO₂ sensor per air handler is recommended. Multiple sensors may be necessary if the ventilation system serves spaces with significantly different occupancy densities or operating schedules. Where multiple sensors are used, the ventilation should be based on the sensor recording the highest concentration of CO₂. In warehouse areas that contain sources of CO₂ generation other than human occupancy (i.e., propane fork trucks, unvented gas-fired radiant heaters, direct gas-fired heaters, gas-powered scooters, etc.), sensor location should be carefully considered to reflect an average sample of the CO₂ concentration in the space.

Sensors used in areas with high occupant levels and high outdoor air requirements should be installed in the return air ducts to provide an average CO₂ measure for the zone. For sensors mounted in return air ducts, adequate access for sensor calibration and field testing must be provided. The number and location of sensors should take into account the sensor manufacturers' recommendations for their particular products.

The demand ventilation controls should maintain CO₂ concentrations less than or equal to 600 ppm plus the outdoor air CO₂ concentration in all spaces with CO₂ sensors. However, the outdoor air ventilation rate should not drop below the required minimum ventilation rate required by code regardless of CO₂ concentration.

The outdoor air CO₂ concentration can be assumed to be 400 ppm without any direct measurement, except in dense urban areas, or the CO₂ concentration can be monitored using a CO₂ sensor located near the position of the outdoor air intake.

CO₂ sensors should be certified by the manufacturer to have an error of 75 ppm or less and be factory calibrated. Inaccurate CO₂ sensors can cause excessive energy consumption and poor air quality, so the sensors need to be calibrated as recommended by the manufacturer.

Plug Loads

Building owners and other users of this Guide can benefit from additional energy savings by outfitting warehouses with efficient appliances, office equipment, and other devices plugged into electrical outlets. In addition to their own energy requirements, plug loads also are a source of internal heat gains that increase air-conditioning energy use in spaces that are cooled. There is a large variation of these loads depending on the amount of office space in the warehouse as well as the need for charging equipment, communications, and other electrical devices.

The recommendations presented in Table 5-3 for purchase and operation of plug load equipment are an integral part of this Guide, but the energy savings from the plug load recommendations are expected to be in addition to the target 30% savings.

Table 5-3. Recommendations for Efficient Plug Load Equipment (for Office Spaces in Warehouses)

Equipment/Appliance Type	Purchase Recommendation	Operating Recommendation
Desktop computer	ENERGY STAR® only	Implement sleep mode software
Electronic cash registers and point-of-sale devices	Purchase with flat-screens with sleep modes	Many of these items are only used during peak times and excess equipment should be turned off
Laptop computer—use where practical instead of desktops to minimize energy use	ENERGY STAR only	Implement sleep mode software
Computer monitors (may include point-of-sale monitors)	ENERGY STAR flat-screen monitors only	Implement sleep mode software
Printer	ENERGY STAR only	Implement sleep mode software
Copy machine	ENERGY STAR only	Implement sleep mode software
Fax machine	ENERGY STAR only	Implement sleep mode software
Water cooler	ENERGY STAR only	N/A
Refrigerator	ENERGY STAR only	N/A
Vending machines	ENERGY STAR only	Delamp display lighting

PL1 Purchase Energy-Efficient Equipment (Climate Zones: all)

Many of the plug load items in warehouses can be specified to be energy efficient. ENERGY STAR[®] labels are applicable for computer equipment, office equipment, and vending machines. Refrigerators for break rooms should also be ENERGY STAR rated. To further reduce energy use, make sure that the ENERGY STAR sleep modes are enabled on computer and copier equipment. The use of such equipment in most warehouse operations is limited and short delays to sleep mode are appropriate.

PL2 Use Time Clocks to Disable Plug Loads (Climate Zones: all)

Time clocks can be used to effectively disable loads when these loads are not needed. Office lighting can be turned off when the warehouse is closed. It may be possible to use common electrical circuits on central time clocks or the energy management system. This technique can also be used to turn off vending machines, coffee makers, point-of-sale devices, calculators, credit card dialers, and other miscellaneous loads when the building is not occupied. Care must be exercised not to turn on all of the loads when the HVAC and lighting are energized to avoid a peak demand on start-up.

PL3 Use Motion-Based Plug Strips (Climate Zones: all)

Plug strips with motion sensors can be deployed in break rooms and offices to turn off plug loads such as vending machines, computer monitors, calculators, and other equipment that plugs in (usually identified with power packs or cubes). Motion sensor circuits can also be used for aisles and walkways in self-storage units.

PL4 Delay Loads to Off-Peak Hours, if Possible (Climate Zones: all)

Delaying loads to off-peak hours probably will not save energy but may save on utility costs. Examples might be electric pallet jacks, forklifts, and chargeable cleaning equipment. Most of these items are used and plugged in near the end of daily operation, causing peak loads coincident with lighting loads. Time clocks can be put on these circuits to delay operation to times when the warehouse is not occupied. Other examples might include dishwashers in kitchen areas and washing machines, available to staff in some cases.

PL5 Identify Loads That Are Not Needed (Climate Zones: all)

Some loads can be disconnected. Quite often in cooler climates, water coolers run refrigerated units when the temperature of the street water is adequate. Excess equipment should be disconnected. Point-of-sale equipment should only be energized when it will be needed. Vending machines can be delamped in non-public areas.

References

- ASHRAE. 2007. *ANSI/ASHRAE Standard 62.1-2007, Ventilation for Acceptable Indoor Air Quality*. Atlanta: American Society of Heating, Refrigerating and Air-Conditioning Engineers, Inc.
- DOE. ENERGY STAR[®]. Washington, DC: U.S. Department of Energy. www.energystar.gov.

Exterior Lighting

Good Design Practice

The following recommendations are not included in the Recommendation Tables in Chapter 3. When designing for parking lots and grounds, follow recommendations EX1 through EX4.

EX1 Exterior Lighting Power (Climate Zones: all)

Limit exterior lighting power to 0.10 W/ft² for parking lot and grounds lighting. Calculate only for paved or improved areas, excluding grounds that do not require lighting. Use internally illuminated or downward-facing sign lighting to comply with light trespass and light pollution concerns.

EX2 Sources (Climate Zones: all)

All general lighting luminaires should utilize pulse-start metal halide, fluorescent, induction, or CFL amalgam lamps with electronic ballasts.

Standard high-pressure sodium lamps are not recommended due to their reduced visibility and poor color-rendering characteristics. Incandescent lamps are not recommended.

For colder climates, fluorescent and CFL luminaires must be specified with cold-temperature ballasts. Use CFL amalgam lamps.

EX3 Parking Lighting (Climate Zones: all)

Parking lot lighting locations should be coordinated with landscape plantings so that tree growth does not block effective lighting from pole-mounted luminaires.

Parking lot lighting should not be significantly brighter than lighting of the adjacent street. Follow IESNA RP-33-1999 recommendations for uniformity and illuminance recommendations.

For parking lot and grounds lighting, do not increase luminaire wattage in order to use fewer lights and poles. Increased contrast makes it harder to see at night beyond the immediate fixture location. Flood lights and non-cutoff wall-packs should not be used, as they cause hazardous glare and unwanted light encroachment on neighboring properties. Limit lighting in parking and drive areas to not more than 320 W pulse-start metal halide lamps at a maximum 20 ft mounting height in urban and suburban areas (fixture height should be proportional to the building height). Use luminaires that produce 0% uplight (formally known as *full-cutoff*) to help eliminate light pollution. Parking luminaires should incorporate house side shielding and/or forward optics and should be located facing into the property to help eliminate light trespass.

EX4 Controls (Climate Zones: all)

Use an astronomical time switch or a combination of a photosensor and a time switch for all exterior lighting. Astronomical time switches are capable of retaining programming and the time setting during loss of power for a period of at least seven days. If a building energy management system is being used to control and monitor mechanical and electrical energy use, it can also be used to schedule and manage outdoor lighting energy use. Turn off exterior lighting not designated for security purposes when the building is unoccupied.

References

- IESNA. 1998. *IESNA RP-20-1998, Recommended Practices and Design Guidelines*. New York: Illuminating Engineering Society of North America.
- IESNA. 1999. *IESNA RP-33-99, Recommended Practices and Design Guidelines*. New York: Illuminating Engineering Society of North America.
- IESNA. 1994. *IESNA DG-5-94, Recommended Practices and Design Guidelines*. New York: Illuminating Engineering Society of North America.
- IESNA. 2003. *IESNA G-1-03, Recommended Practices and Design Guidelines*. New York: Illuminating Engineering Society of North America.
- RPI. 1996. *Outdoor Lighting Pattern Book*. Troy, NY: Rensselaer Polytechnic Institute.

Appendix A

Envelope Thermal Performance Factors

The Recommendation Tables in Chapter 3 present the opaque envelope recommendations in a standard format. This is a simple approach, but it limits the construction options. In order to allow for alternative constructions, the recommendations can also be represented by thermal performance factors, such as U-factors for above-grade components or F-factors for slabs-on-grade; see Table A-1. Any alternative construction that is less than or equal to these thermal performance factors will be acceptable alternatives to the recommendations.

Table A-1. Envelope Thermal Performance Factors

Opaque Construction Options					
Roof Assemblies		Walls, Exterior		Walls, Interior	
Insulation Entirely Above Deck		Mass Walls		Partition	
R	U	R	U	R	U
3.8 c.i.	0.218	5.7 c.i.	0.151	13	0.121
5.0 c.i.	0.173	7.6 c.i.	0.123		
7.6 c.i.	0.119	9.5 c.i.	0.104		
10.0 c.i.	0.093	11.4 c.i.	0.090		
15.0 c.i.	0.063	13.3 c.i.	0.080		
20.0 c.i.	0.048	15.2 c.i.	0.071		
Metal Building		Metal Building			
R	U	R	U		
6	0.167	13	0.113		
10	0.097	16	0.093		
13	0.083	19	0.084		
16	0.072	19+5.6 c.i.	0.057		
19	0.065	19+11.2 c.i.	0.043		
13+13	0.055				
13+19	0.049				
11+19 ls	0.0354				
Single Rafter		Steel Framed			
R	U	R	U		
21	0.052	13	0.124		
30	0.036	13+3.8 c.i.	0.084		
38	0.028	13+7.5 c.i.	0.064		
38+5.0 c.i.	0.025				
38+10.0 c.i.	0.022				
		Wood Framed and Other			
		R	U		
		13	0.089		
		13+3.8 c.i.	0.064		
		13+7.5 c.i.	0.051		
		13+15.6 c.i.	0.036		

Slabs

Unheated

R-in.	F
10.0-24	0.54
15.0-24	0.52
20.0-24	0.51

Appendix B

Climate Zones for Mexico and Canada

Tables B-1 and B-2 show the climate zone numbers for a wide variety of Mexican and Canadian locations. Additional information on international climate zones can be found in ASHRAE/IESNA Standard 90.1, Normative Appendix B—Building Envelope Climate Criteria. The information that follows is from Tables B-2 and B-3 in that appendix.

Table B-1. Mexican Climate Zones

Country		Country	
City	Zone	City	Zone
Mexico		Mexico	
Mexico City (Distrito Federal)	3	Tampico (Tamaulipas)	1
Guadalajara (Jalisco)	1	Veracruz (Veracruz)	4
Monterrey (Nuevo Laredo)	3	Merida (Yucatan)	1

Appendix C

Additional Resources

BOOKS AND STANDARDS

- AAMA. 2003. *AAMA 507, Standard Practice for Determining the Thermal Performance Characteristics of Fenestration Systems Installed in Commercial Buildings*. Schaumburg, IL: American Architectural Manufacturers Association.
- ACCA. 2008. *Manual N—Commercial Load Calculation*, 5th ed. Arlington, VA: Air Conditioning Contractors of America.
- ASHRAE. 1999. *ANSI/ASHRAE/IESNA Standard 90.1-1999, Energy Standard for Buildings Except Low-Rise Residential Buildings*. Atlanta: American Society of Heating, Refrigerating and Air-Conditioning Engineers, Inc.
- ASHRAE. 2004. *2004 ASHRAE Handbook—HVAC Systems and Equipment*. Atlanta: American Society of Heating, Refrigerating and Air-Conditioning Engineers, Inc.
- ASHRAE. 2004. *Advanced Energy Design Guide for Small Office Buildings*. Atlanta: American Society of Heating, Refrigerating and Air-Conditioning Engineers, Inc.
- ASHRAE. 2005. *2005 ASHRAE Handbook—Fundamentals*. Atlanta: American Society of Heating, Refrigerating and Air-Conditioning Engineers, Inc.
- ASHRAE. 2006. *Advanced Energy Design Guide for Small Retail Buildings*. Atlanta: American Society of Heating, Refrigerating and Air-Conditioning Engineers, Inc.
- ASHRAE. 2006. *ANSI/ASHRAE Standard 169-2006, Weather Data for Building Design Standards*. Atlanta: American Society of Heating, Refrigerating and Air-Conditioning Engineers, Inc.
- ASHRAE. 2007. *2007 ASHRAE Handbook—HVAC Applications*. Atlanta: American Society of Heating, Refrigerating and Air-Conditioning Engineers, Inc.
- ASHRAE. 2007. *ANSI/ASHRAE Standard 52.2-2007, Method of Testing General Ventilation Air-Cleaning Devices for Removal Efficiency by Particle Size*. Atlanta: American Society of Heating, Refrigerating and Air-Conditioning Engineers, Inc.
- ASHRAE. 2007. *ANSI/ASHRAE Standard 62.1-2007, Ventilation for Acceptable Indoor Air Quality*. Atlanta: American Society of Heating, Refrigerating and Air-Conditioning Engineers, Inc.

- ASHRAE. 2007. *ANSI/ASHRAE/IESNA Standard 90.1-2007, Energy Standard for Buildings Except Low-Rise Residential Buildings*. Atlanta: American Society of Heating, Refrigerating and Air-Conditioning Engineers, Inc.
- ASHRAE. 2008. *Advanced Energy Design Guide for K-12 School Buildings*. Atlanta: American Society of Heating, Refrigerating and Air-Conditioning Engineers, Inc.
- ASTM. 2001. *ASTM E 1980, Standard Practice for Calculating Solar Reflectance Index of Horizontal and Low-Sloped Opaque Surfaces*. West Conshohocken, PA: American Society for Testing and Materials.
- ASTM. 2003. *ASTM E 2178, Standard Test Method for Air Permeance of Building Materials*. West Conshohocken, PA: American Society for Testing and Materials.
- DLC. 2008. *Warehouse Skylighting knowhow™ Design Guide*. DesignLights™ Consortium. www.designlights.org/guides.html.
- DOE. ENERGY STAR[®]. Washington, DC: U.S. Department of Energy. www.energystar.gov.
- Evans, Benjamin. 1997. *Daylighting Design, Time Saver Standards for Architectural Design Data*. New York: McGraw-Hill.
- IESNA. 1994. *IESNA DG-5-94, Recommended Lighting for Walkways and Class I Bikeways. Recommended Practices and Design Guidelines*. New York: Illuminating Engineering Society of North America.
- IESNA. 1996. *EPRI Lighting Controls—Patterns for Design*. New York: Illuminating Engineering Society of North America.
- IESNA. 1997. *EPRI Daylight Design: Smart and Simple*. New York: Illuminating Engineering Society of North America.
- IESNA. 1998. *IESNA RP-20-1998, Lighting for Parking Facilities. Recommended Practices and Design Guidelines*. New York: Illuminating Engineering Society of North America.
- IESNA. 1999. *IESNA RP-33-99, Lighting for Exterior Environments. Recommended Practices and Design Guidelines*. New York: Illuminating Engineering Society of North America.
- IESNA. 2001. *ANSI/IESNA RP-2-01, Recommended Practice on Lighting Merchandising Areas (A Store Lighting Guide)*.
- IESNA. 2003. *IESNA G-1-03, Guideline on Security Lighting for People, Property and Public Spaces. Recommended Practices and Design Guidelines*. New York: Illuminating Engineering Society of North America.
- LBL. 1997. Tips for daylighting with windows. *Windows & Daylighting*. Berkeley, CA: Lawrence Berkeley National Laboratories. <http://windows.lbl.gov/daylighting/designguide/designguide.html>.
- NBI. 2003. *Advanced Lighting Guidelines*. White Salmon, WA: New Buildings Institute. www.newbuildings.org/lighting.htm.
- NEEP. 2003. *Know-How Guide for Retail Lighting*. Lexington, MA: Northeast Energy Efficiency Partnerships. Available as free download from www.designlights.org.
- NLPIP. 2008. Photosensor tutorial. National Lighting Product Information Program, Rensselaer Polytechnic Institute, Troy, NY. www.lrc.rpi.edu/programs/NLPIP/tutorials/photosensors.
- RPI. 1996. *Outdoor Lighting Pattern Book*. Troy, NY: Rensselaer Polytechnic Institute. Available for purchase from www.lightingresearch.org.
- Torcellini, P.A., and D.B. Crawley. 2006. Understanding zero-energy buildings. *ASHRAE Journal* 48(9):62–69.
- Torcellini, P., S. Pless, M. Deru, B. Griffith, N. Long, and R. Judkoff. *Lessons Learned from Case Studies of Six High-Performance Buildings*. 2006. NREL Report No. TP-550-37542. Golden, CO: National Renewable Energy Laboratory. www.nrel.gov/docs/fy06osti/37542.pdf.

WEB SITES

- 3E Plus (Insulation Thickness Computer Program)
www.pipeinsulation.org
- AACA—Air Conditioning Contractors of America
www.aaca.org
- AAMA—American Architectural Manufacturers Association
www.aamanet.org
- Advanced Lighting Guidelines*
www.newbuildings.org/lighting.htm
- AIA—American Institute of Architects
www.aia.org
- AIA Committee on the Environment Top Ten Awards
www.aiaopten.org
- ANSI—American National Standards Institute
www.ansi.org
- API—Alliance for the Polyurethanes Industry
www.polyurethane.org
- ASHRAE—American Society of Heating, Refrigerating and Air-Conditioning Engineers, Inc.
www.ashrae.org
- ASTM—American Society for Testing and Materials
www.astm.org
- Building Energy Codes Program, EERE, DOE
www.energycodes.gov
- Building Energy Codes Resource Center, PNNL
<http://resourcecenter.pnl.gov/cocoon/morf/ResourceCenter>
- CB ECS—Commercial Buildings Energy Consumption Survey, EIA
www.eia.doe.gov/emeu/cbecs/contents.html
- CRRC—Cool Roof Rating Council
www.coolroofs.org
- DesignLights™ Consortium
www.designlights.org
- DOE—U.S. Department of Energy
www.energy.gov
www.energycodes.gov
- EIA—Energy Information Administration
www.eia.doe.gov
- EERE—Energy Efficiency and Renewable Energy, DOE
www.eere.energy.gov
- ENERGY STAR®
www.energystar.gov
- EPS Molders Association
www.epsmolders.org
- High Performance Buildings Database, EERE Buildings Program, DOE
www.eere.energy.gov/buildings/database/
- IESNA—Illuminating Engineering Society of North America
www.iesna.org
- LBNL—Lawrence Berkeley National Laboratory
www.lbl.gov

LEED—Leadership in Energy and Environmental Design Green Buildings Rating System™

www.usgbc.org/LEED

Lessons Learned from Case Studies of Six High-Performance Buildings, NREL

www.nrel.gov/docs/fy06osti/37542.pdf.

LRC—Lighting Research Center

www.lightingresearch.org

MBMA—Metal Building Manufacturers Association

www.mbma.com

NAIMA—North American Insulation Manufacturers Association

www.naima.org

NBI—New Buildings Institute

www.newbuildings.org

NEEP—Northeast Energy Efficiency Partnerships

www.neep.org

NEMA—National Electrical Manufacturers Association

www.nema.org

NFRC—National Fenestration Rating Council

www.nfrc.org

NREL—National Renewable Energy Laboratory

www.nrel.gov

ORNL—Oak Ridge National Laboratory

www.ornl.gov/sci/engineering_science_technology/buildings.shtm

PIMA—Polyisocyanurate Insulation Manufacturers Association

www.polyiso.org

RPI—Rensselaer Polytechnic Institute

www.rpi.edu

SRI Calculator, ORNL

www.ornl.gov/sci/roofs+walls/calculators/ssreflect/index.htm

“Tips for Daylighting with Windows,” *Daylight and Windows*

<http://windows.lbl.gov/daylighting/designguide/designguide.html>

USGBC—U.S. Green Building Council

www.usgbc.org

The Whole Building Design Guide

<http://wbdg.org/>

XPSA—Extruded Polystyrene Foam Association

www.xpsa.com

For more information or to provide feedback on the *Advanced Energy Design Guide* series, please visit www.ashrae.org/aedg.

Advanced Energy Design Guide for Small Warehouses and Self-Storage Buildings

This guide was prepared under ASHRAE Special Project 114.

The *Advanced Energy Design Guide for Small Warehouses and Self-Storage Buildings* is the fourth in a series designed to provide recommendations for achieving 30% energy savings over the minimum code requirements of ANSI/ASHRAE/IESNA Standard 90.1-1999. The energy savings target of 30% is the first step in the process toward achieving a net zero energy building, which is defined as a building that, on an annual basis, draws from outside resources equal or less energy than it provides using on-site renewable energy sources. ANSI/ASHRAE/IESNA Standard 90.1-1999, the energy-conservation standard published at the turn of the millennium, provides the fixed reference point for all of the Guides in this series. The primary reason for this choice as a reference point is to maintain a consistent baseline and scale for all of the 30% AEDG series documents.

This Guide focuses on warehouses up to 50,000 ft² and self-storage buildings that use unitary heating and air-conditioning equipment. Buildings of this type with these HVAC system configurations represent a significant amount of commercial warehouse space in the United States.

The recommendations in this Guide will allow contractors, consulting engineers, architects, and designers to easily achieve advanced levels of energy savings without having to resort to detailed calculations or analyses. All of the energy saving recommendations for each of the eight U.S. climate zones are contained on a single page, thus facilitating the Guide's use. Additional recommendations identify other opportunities to incorporate greater energy savings into the design of the building.

Those looking for help in implementing the recommendations of this Guide will find an expanded section of tips and approaches in the "How to Implement Recommendations" chapter of the Guide. To further facilitate its use, the Guide cross references the how-to information with the numbered tips and the color-coded climate zone maps. Examples of advanced warehouse energy designs are also provided in various case studies to illustrate the recommendations and to demonstrate the flexibility offered in achieving the advanced energy savings levels provided within the Guide.

For more information on the entire *Advanced Energy Design Guide* series, please visit www.ashrae.org/aedg.

ISBN 978-1-933742-22-9



9781933742229

90436